



Lateral Arm Replacement

SUNSETTER ESSENTIALS MOTORIZED AWNINGS

For Technical Support:

[HTTPS://SUPPORT.SUNSETTER.COM](https://support.sunsetter.com)

E-MAIL CONTACTUS@SUNSETTER.COM

CALL TOLL FREE 800-670-7071

 WARNING

FAILURE TO FOLLOW THESE INSTRUCTIONS COULD RESULT IN SERIOUS PERSONAL INJURY, INCLUDING DEATH.

PLEASE READ THESE INSTRUCTIONS IN ENTIRITY BEFORE ATTEMPTING TO COMPLETE THIS PROCESS.

Parts Supplied

- Lateral Arm (Left or Right)
- Plastic Safety Sleeves

Tools Needed

- Step Ladder
- 6mm Hex Key
- 3mm Hex Key
- Towel
- Pencil
- Measuring Tape

1

Prepare Awning

PLEASE NOTE THAT LEFT AND RIGHT REFERENCES ARE AS YOU ARE FACING THE HOUSE.

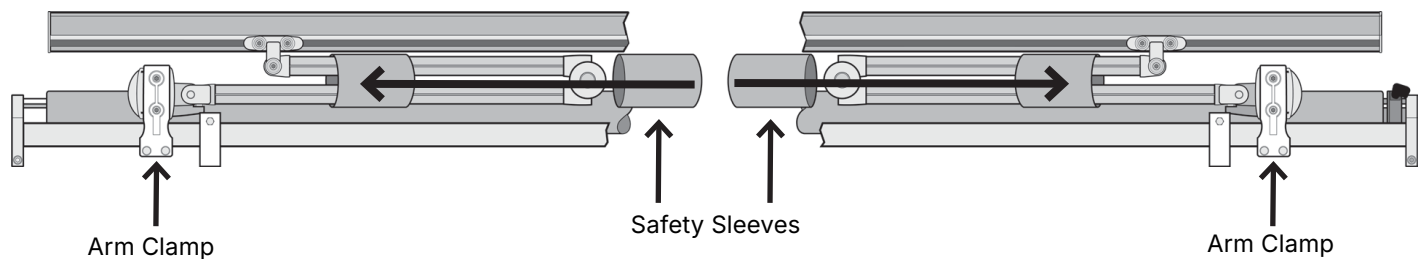

Figure 1

1. Make sure the awning is completely retracted against the house.
2. **Unplug the power cord from the power (GFI) outlet.**

3. **Slide the supplied safety sleeves on both lateral arms, sliding them as far as possible toward the arm clamps (see Figure 1).**

! WARNING

**FAILURE TO DISCONNECT
POWER TO THE AWNING CAN
RESULT IN PERSONAL INJURY!**

! WARNING

**FAILURE TO FULLY INSTALL
SAFETY SLEEVES CAN
RESULT IN PERSONAL INJURY!**

2

Separate lateral arm from front bar connector

4. On the lateral arm being replaced, remove the 6mm hex socket cap bolt and top nut from the front bar connector (see **Figure 2**). Be sure to save the nylon bushings inserted into the front bar connector for reassembly.
5. Separate the front bar from the end of the lateral arm.
6. Place a rolled up towel around the front bar connector and tuck it between the roller bar and wall, to hold the disconnected front bar up and out of the way and to prevent the dangling front bar from scratching the lateral arm. If this step cannot be performed, have a helper hold the front bar while continuing with the following steps. Ensure the front bar connector and front bar do not damage the awning fabric or paint. Touch-up paint is available from SunSetter.

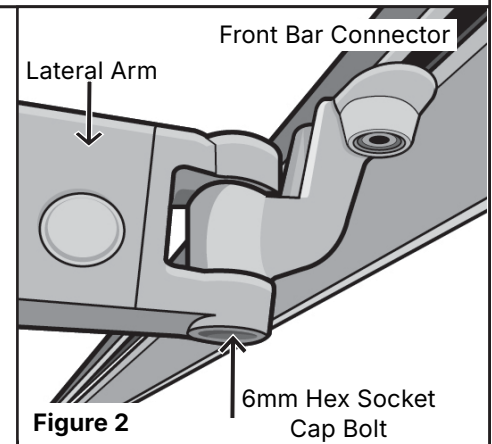

3

Separate lateral arm from arm clamp

7. Swing the lateral arm away from the house and expose the 3mm hex set screw (see **Figure 3**).
8. Remove the plastic cap above the set screw.
9. While supporting the balanced weight of the lateral arm in one hand, use a 3mm hex key to loosen (but do not remove) the set screw (see **Figure 3**).
10. Lift the lateral arm to take pressure off the arm clamp, while lowering the attachment pin holding the lateral arm to the arm clamp (see **Figure 3**). Save this pin for installation of the replacement lateral arm.
Tip: Gently shaking the arm can help release pressure from the pin if it does not slide out easily.
11. Separate the lateral arm from the arm clamp and place aside.

Figure 3

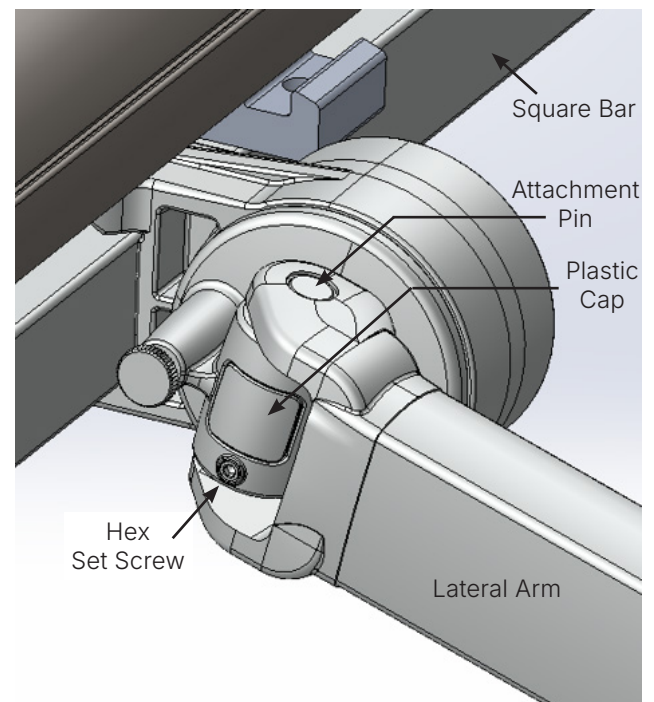

4

Attach replacement lateral arm to arm clamp

Use the Arm Clamp Locations Chart to identify the correct arm clamp locations for your awning size.

Failure to use correct arm clamp locations may prevent proper awning operation.

12. Position the lateral arm over the knuckle of the arm clamp and insert the attachment pin (see **Figure 3**).
13. Make sure the attachment pin is centered in the arm clamp, then tighten the 3mm hex set screw (see **Figure 3**).
14. Insert the plastic cover above the set screw (see **Figure 3**).
15. Swing the lateral arm back towards the house.

Arm Clamp Locations Chart

Arm clamp locations are measured from the end of the square bar to the edge of the arm clamp.

Size	Arm Clamp Location
10'	3.5" (motor end) 2.75" (idle end)
12'	5"
14'	16"
16'	24"
20'	24"

5

Attach lateral arm to front bar connector

16. Make sure the plastic bushings are in place, on the front bar connector, where the retaining bolt passes through the front bar connector and lateral arm.
17. Insert the retaining bolt through the lateral arm and front bar connector. Replace the top nut above the front bar connector. Tighten securely with a 6mm hex key.

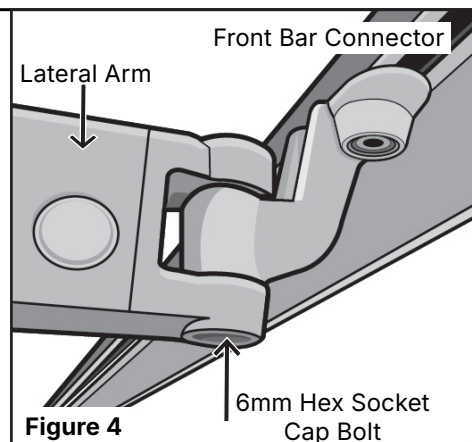

6

Test for proper operation

18. Remove plastic safety sleeves from lateral arms.
19. Plug in the power cord, then test for proper operation.



Final adjustments

Are you happy with the height and level of the front bar?

If **no**, and you would like to change the pitch (angle) of your awning, refer to “**Changing the pitch of your awning**” on the following page.

Are you happy with the appearance and operation of the lateral arms?

If either closed lateral arm sticks out too far or hits the square bar, the arm clamp’s nylon bumper can be adjusted to correct this (see **Figure 5**). Turning the bumper clockwise will allow the arm to come in closer to the house. Turning the bumper counter clockwise will push the arm out further from the house.

Does the fabric appear centered on the roller bar and front bar?

If **no**, adjust the fabric through the following steps:

This procedure **works best with helpers**.

1. Open the awning all the way.
2. Unplug the power cord from the outlet.
3. Using the crank wand, open the awning; continue until the roller bar is fully exposed.
4. Adjust the fabric as needed, so that it is centered on the roller bar and the front bar.
5. Have two helpers hold the fabric **in place on the roller bar**, while the third person **manually cranks the awning closed until the fabric is tight and the front bar begins to close**.
6. Plug in the power cord and close the awning the rest of the way.
7. Test for proper operation.
8. If further adjustment is needed, repeat the fabric adjustment, in very slight increments, as needed.
9. If problems persist, please call Customer Service at **800-670-7071** for support.

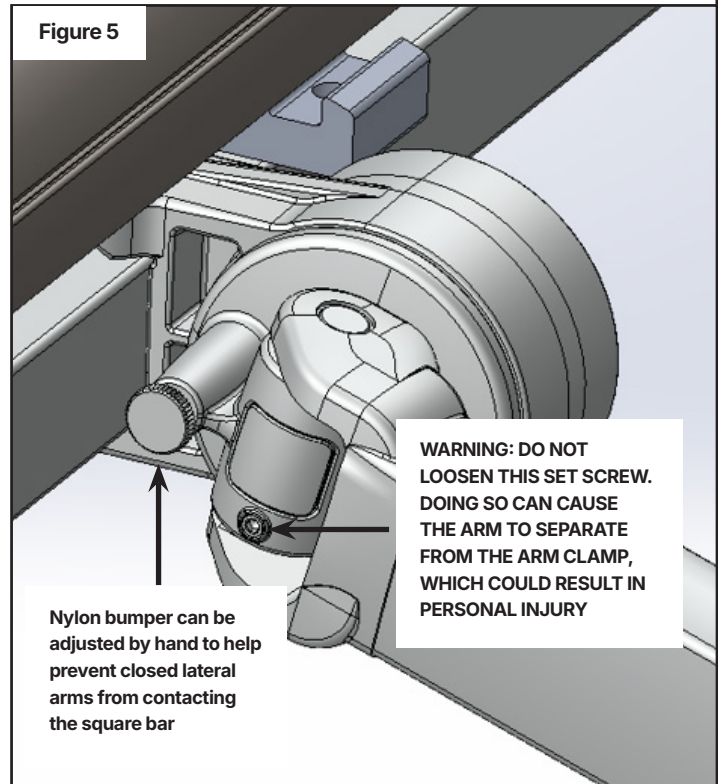



Changing the pitch of your awning

Follow these instructions to change the pitch or angle of your awning (see **Figure A**).
A visual guide is available on <https://support.sunsetter.com>, under "Helpful Videos".

Figure A Pitch is set at the factory so the bottom of the front bar is 29" lower than the top of the fabric on the roller bar.

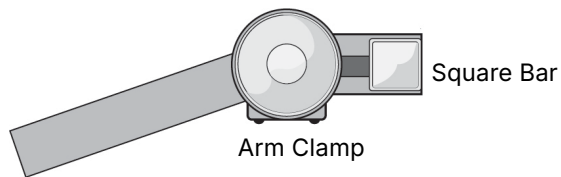

Lateral Arm, extended at factory set height.

Pitch raised to maximum height.

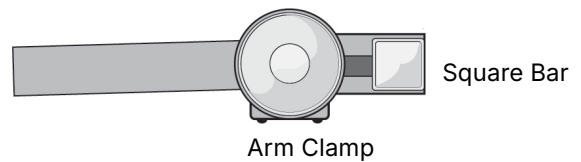

Lateral Arm, extended at maximum height.

Tools Needed

- 6mm Hex Key
- Large Adjustable Wrench
- Step Ladder(s)
- Helper(s)

Note: Adjust each lateral arm, one at a time, until both are at the desired height and the front bar is level.

Note: Depending on the awning size and model, the weight of the front bar varies. (Example: Wider awnings will have heavier front bars) This will impact how high you can raise the front bar, using the adjustment capabilities of the arm clamps. See Figure D for the pitch channel range. If you reach the maximum adjustment and are still not happy with the height of the front bar, you can shim the wall brackets upward to raise the front bar further. Make sure that all wall brackets are shimmed evenly.



Changing the pitch of your awning

RAISING THE FRONT BAR

WARNING

RAISING THE FRONT BAR WILL REDUCE THE PITCH (ANGLE) OF THE FABRIC THUS INCREASING THE RISK OF RAINWATER POOLING ON THE FABRIC. TO PREVENT THE AWNING FROM COLLAPSING DUE TO RAINWATER LOAD, YOU MUST RETRACT THE AWNING WHEN UNATTENDED. FAILURE TO DO SO COULD RESULT IN PERSONAL INJURY.

1. Close the awning.
2. Have your helper slightly lift the front bar close to the front bar connector, to remove pressure on the arm clamp.
3. Remove the plastic cover from the arm clamp. Remove by hand, no tools required (see **Figure C**).
4. Using an adjustable wrench, tighten the large bolt in the center of the arm clamp for safety (see **Figure D**).
5. Release the front bar and stand to the side of the awning.
6. Open the awning.
7. Loosen the large bolt in the arm clamp, not more than one quarter turn (see **Figure D**).
8. Slightly lift the front bar (close to the front bar connector) to remove pressure on the arm clamp, then loosen Set Screw #1 until the front bar is above the desired height. See **Figure D** to see the channel in the arm clamp showing high and low range of pitch.
9. While holding the front bar above the desired height, tighten Set Screw #2.
Note: Setting the front bar above the desired height allows room for settling when you release the front bar.
10. Release the front bar and tighten Set Screw #1.
11. Check height. Adjust as necessary, then go to step 12.
12. The front bar should be level. If not, adjust the height of either arm, according to the steps, above.
13. Slightly lift the front bar (close to the front bar connector) to remove pressure on the arm clamp.
14. Tighten the large bolt in the arm clamps (see **Figure D**).
15. Release the front bar and check for level. If tilted, adjust the height of either arm, according to the steps above.
16. Push the front bar down. If it moves from the desired height, repeat the steps above.
17. Replace the plastic cover to the arm clamp. Align the plastic guides, press by hand (see **Figure C**).

Note: Depending on adjustments, the Open/Close stop limits may need adjusting to correct fabric sagging. Follow the "Adjusting the Open and Close Limits" section of your awning's owner's manual to change these settings.



Changing the pitch of your awning

LOWERING THE FRONT BAR

1. Close the awning.
2. Have your helper slightly lift the front bar close to the front bar connector, to remove pressure on the arm clamp.
3. Remove the plastic cover from the arm clamp. Remove by hand, no tools required (see **Figure C**).
4. Using an adjustable wrench, tighten the large bolt in the center of the arm clamp for safety (see **Figure D**).
5. Release the front bar and stand to the side of the awning.
6. Open the awning.
7. Loosen the large bolt in the arm clamp, not more than one quarter turn (see **Figure D**).
8. Slightly lift the front bar (close to the front bar connector) to remove pressure on the arm clamp, then loosen Set Screw #2 until the front bar can be lowered to reach the desired height. See **Figure D** to see the channel in the arm clamp showing high and low range of pitch.
9. Release the front bar.
10. Tighten Set Screw #1.
11. Check height. Adjust as necessary, then go to step 12.
12. The front bar should be level. If not, adjust the height of either arm, according to the steps, above.
13. Slightly lift the front bar (close to the front bar connector) to remove pressure on the arm clamp.
14. Tighten the large bolt in the arm clamps (see **Figure D**).
15. Release the front bar and check for level. If tilted, adjust the height of either arm, according to the steps above.
16. Push the front bar down. If it moves from the desired height, repeat the steps above.
17. Replace the plastic cover to the arm clamp. Align the plastic guides, press by hand (see **Figure C**).

Note: Depending on adjustments, the Open/Close position stops may need to be adjusted to correct any sagging that may occur to the fabric. Follow the "Adjusting the Open and Close Limits" of your awning's owner's manual to change these settings.



Changing the pitch of your awning

Figure B

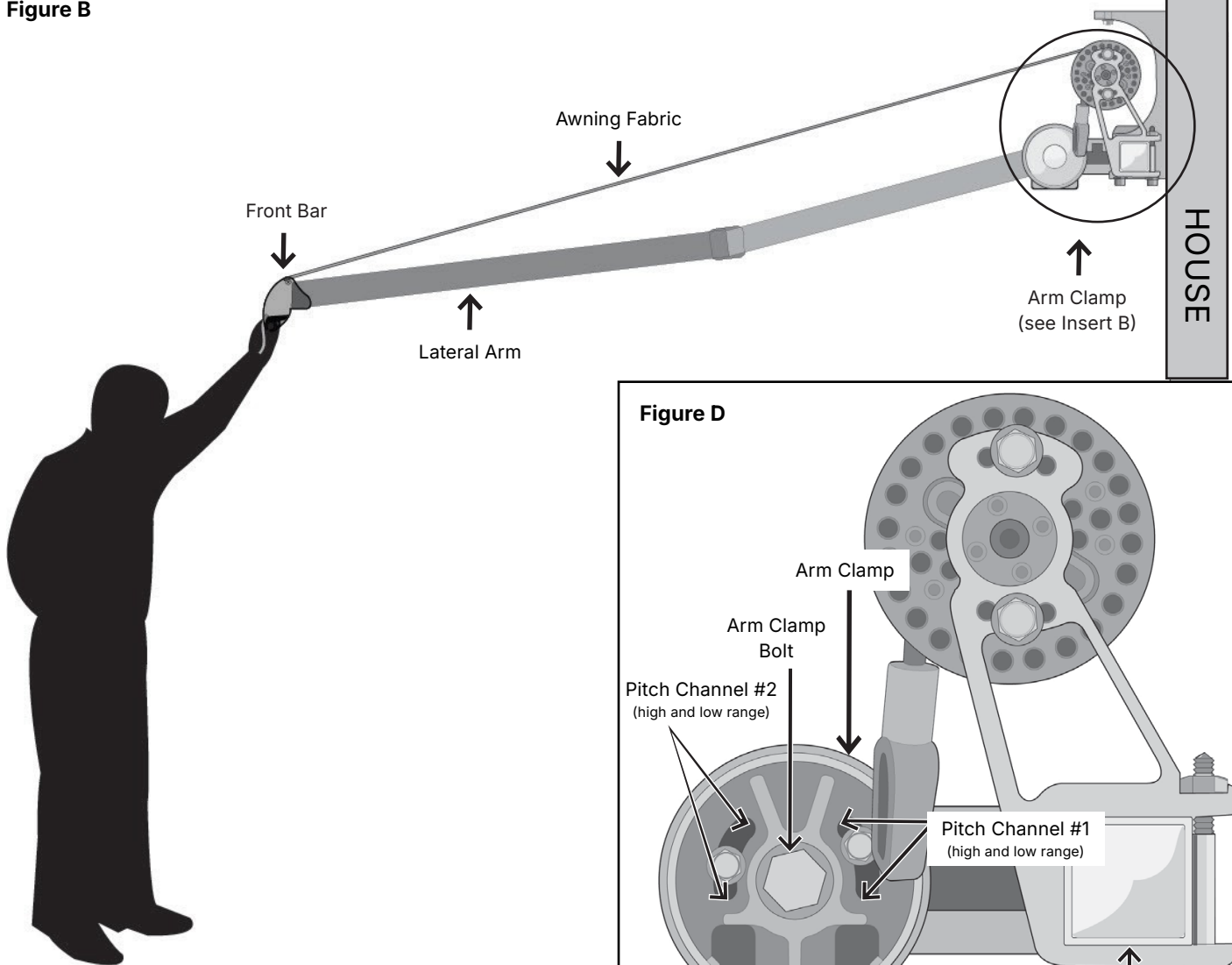
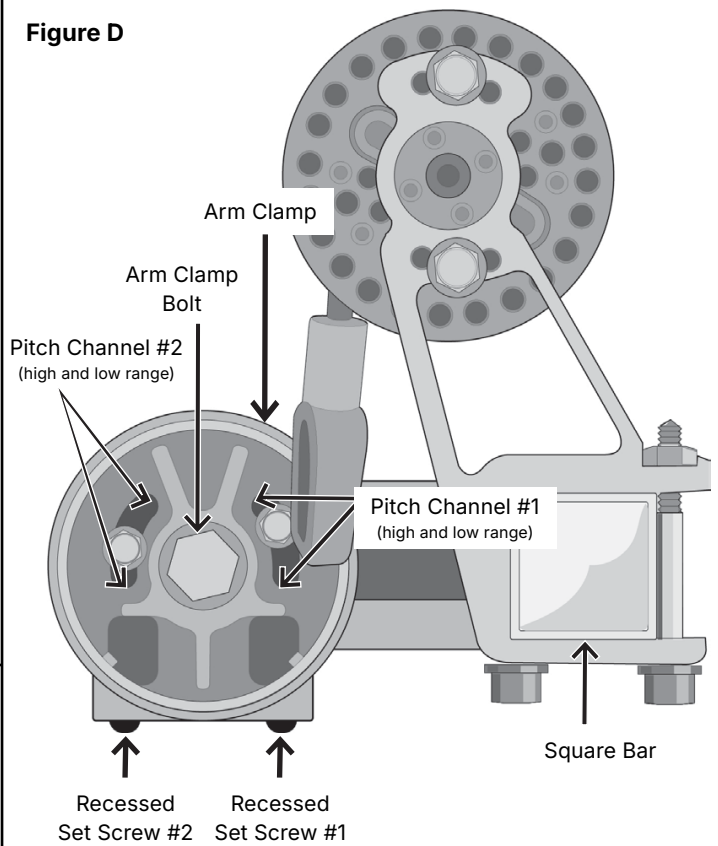

Figure D



Note: The high and low range of pitch can be viewed in Pitch Channel #1 and #2, as shown above.

CAUTION: Do not attempt to raise the pitch beyond the physical limits observed in Pitch Channel #1 and #2, as shown above. Doing so could damage the arm clamp.

Figure C

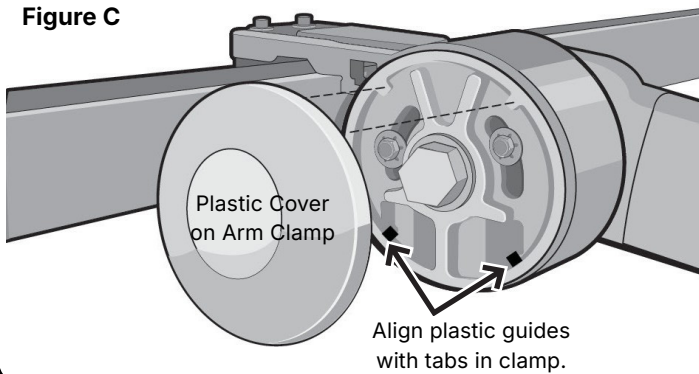

Thank you for choosing SunSetter.