



OWNER'S MANUAL & INSTALLATION INSTRUCTIONS

Do Not Discard, Retain for Future Reference

Solar-Powered EasyShade[®]

(Manufactured June 3, 2024 - Present)

WARNING

**FAILURE TO FOLLOW THESE INSTRUCTIONS COULD RESULT IN SERIOUS
PERSONAL INJURY, INCLUDING DEATH**

For Technical Support, please visit us at <https://support.sunsetter.com>,
e-mail at contactus@sunsetter.com or call Toll Free 800-670-7071

This page left intentionally blank

TABLE OF CONTENTS

READ ME FIRST	2
Pre-Installation Note	2
Figure 1 - Solar-Powered EasyShade Schematic View	3
Tools Needed:	4
Parts Supplied:	4
INSTALLATION	5
Solar Panel and Battery	5
Attach Solar Panel to EasyShade Housing	5
Mount EasyShade Housing to House	5
Install Mounting Brackets - Vertical	5
Install Mounting Brackets - Horizontal	6
Install EasyShade into Brackets	6
Install Cable Guide Brackets and Cables	7
Adjust Lower Stop Limit	8
OPERATION	9
Operating the EasyShade	9
Remote Transmitters are Unique	9
Solar Panel and Battery	10
LED Indicator Blink Codes	10
Optional Items (Sold Separately)	10
CARE AND MAINTENANCE	11
FAQ - FREQUENTLY ASKED QUESTIONS	12
TROUBLESHOOTING	13
Additional Motor Troubleshooting	16
APPENDIX A	17
Adjusting the Up and Down Stop Position for the Solar-Powered EasyShade	17
APPENDIX B	18
Programming the Motor	18
Add/Delete a Control Device (Remote Transmitter)	18
APPENDIX C	19
Programming Instructions - Multi-Channel Remote Transmitter	19
5-Year Limited Manufacturer's Warranty for SunSetter EasyShade	20

WARNING



- Remove and immediately recycle or dispose of used batteries according to local regulations and keep away from children. Do NOT dispose of batteries in household trash or incinerate.
- Even used batteries may cause severe injury or death.
- Call a local poison control center for treatment information.
- Applicable to compatible battery type **CR2430, CR2032, and CR2450.**
- Nominal battery voltage is **3V.**
- Non-rechargeable batteries are not to be recharged.
- Do not force discharge, recharge, disassemble, heat above **60°C (140°F)** or incinerate. Doing so may result in injury due to venting, leakage or explosion resulting in chemical burns.
- Ensure the batteries are installed correctly according to polarity (+ and -).
- Do not mix old and new batteries, different brands or types of batteries, such as alkaline, carbon-zinc, or rechargeable batteries.
- Remove and immediately recycle or dispose of batteries from equipment not used for an extended period of time according to local regulations.
- Always completely secure the battery compartment. If the battery compartment does not close securely, stop using the product, remove the batteries, and keep them away from children.

**⚠ WARNING: FAILURE TO FOLLOW THESE INSTRUCTIONS CAN RESULT IN PERSONAL INJURY!
PLEASE READ THESE INSTRUCTIONS COMPLETELY BEFORE PERFORMING THIS INSTALLATION.**

READ ME FIRST

Congratulations!

You have just purchased a Solar-Powered EasyShade. This EasyShade saves energy by stopping the glare and heat before it can enter your home, yet still lets you enjoy your view, all at the touch of a button.

Customer Support

Our technical experts are available via email at contactus@sunsetter.com or call us at **800-670-7071** should you require assistance. We also invite you to visit the Owner's Corner at <https://www.sunsetter.com/oc/ocloginnew/> for additional information on your Solar-Powered EasyShade. You may need to register your purchase by calling **800-670-7071**. Please be prepared to provide the size (width) of the EasyShade, color of housing, color of fabric panel, and date of purchase.

Factory Limit Settings

The **Up and Down stop limits** on the EasyShade motor were set at the factory to stop 36" from the aluminum housing. This will allow for completion of the installation process, where you will be instructed to adjust the Down position limit to a maximum 84" (7').

Remote Transmitter

SunSetter EasyShades are programmed to **operate on channel 1** of the specific remote provided with the EasyShade. The EasyShade can be operated on any individual channel or multiple channels, and more than one EasyShade can be operated on the same channel. See **Appendix C** for Programming Instructions for the Multi-Channel Remote Transmitter.

Pre-Installation Note

Note: Prior to installing your Solar-Powered EasyShade, please review **Figure 1** (*Solar Powered EasyShade Schematic View*), then inspect to ensure that there are no obstructions on your wall surface, such as light fixtures or door handles, that would interfere with or block the fabric panel as it extends. For proper operation, you must ensure that the aluminum housing and cable guide brackets are mounted on the same vertical plane or surface.

The Solar-Powered EasyShade can be installed with the mounting brackets on a wall (Vertical Surface, see **Figure 4**) or on the underside of a structure (Horizontal Surface, see **Figure 5**). Each of the brackets should be installed no more than 10" from the end of the aluminum housing. For 10' to 12' models, the third mounting bracket should be installed at the midpoint between the two end brackets.

The aluminum housing requires 3-1/2" of clear, unobstructed space along the mounting surface of the wall or underside of the structure/soffit.

Vertical space between the aluminum housing and the lower location of the cable guide bracket must be clear of obstructions to allow the fabric panel to freely extend.

Figure 1 - Solar-Powered EasyShade Schematic View

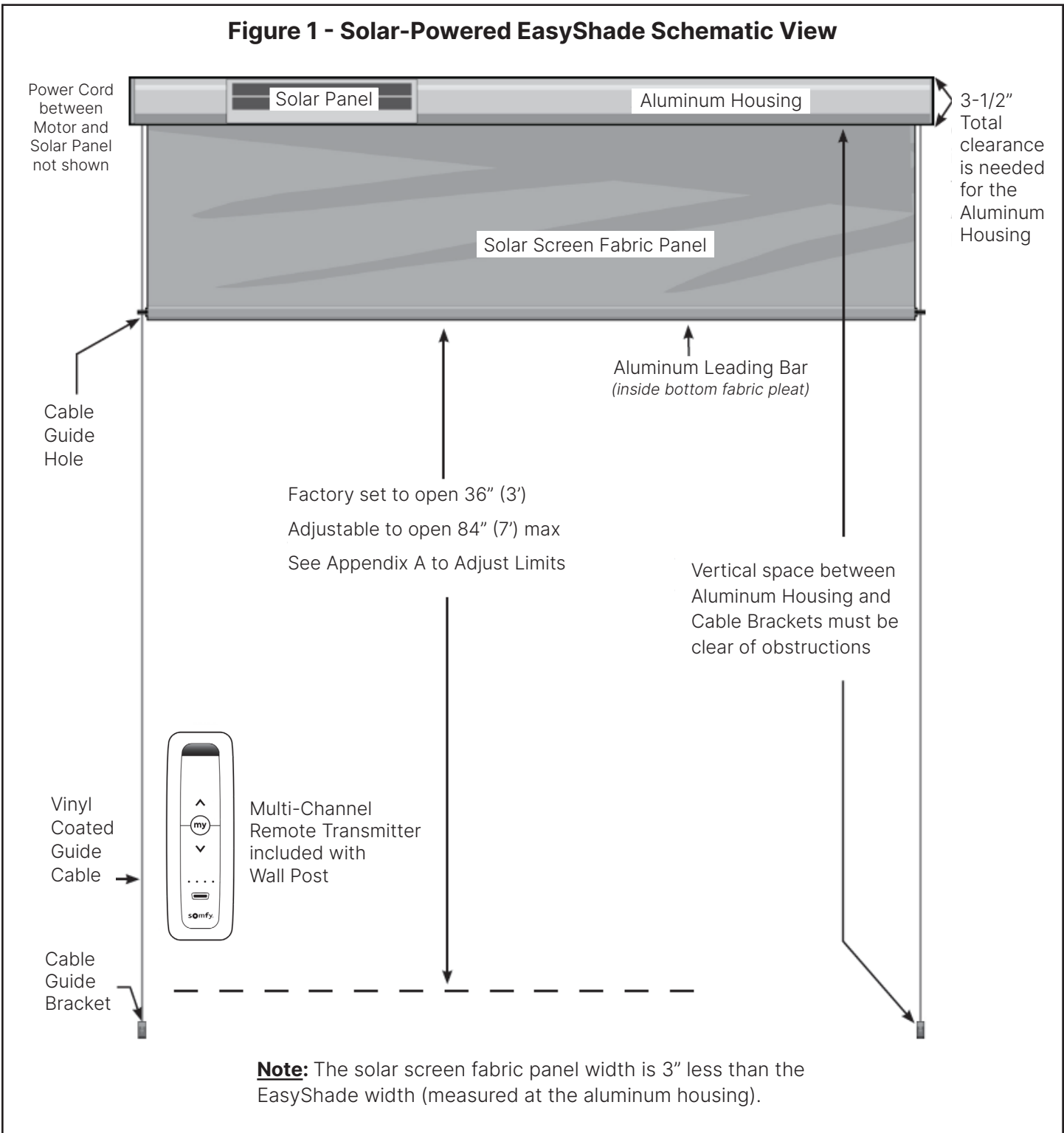

Tools Needed:

- Helper
- Ladder
- Tape Measure
- Pencil
- Electric Drill
- 1/8" Drill Bit
- Phillips Screwdriver
- Level
- 7/16" Open-End Wrench
- Wire Cutter

Parts Supplied:

- Solar-Powered EasyShade Assembly (not shown below)
- Solar Panel with Internal Battery
- Mounting Brackets
- #8 × 1-1/2" Round-Head Screws
- 1/8" Allen Wrench (for the Mounting Bracket Set Screws)
- Two (2) Cable Guides
- Two (2) Cable Guide Brackets
- Two (2) Cable Guide Stops
- 5/64" Allen Wrench (for Cable Guide Stop Set Screws)
- #8 × 1-1/2" Flat-Head Screws
- One (1) 4mm Allen Wrench and Allen set screw (for the Solar Panel Housing)
- One (1) Multi-Channel Remote Transmitter with Wall Mounting Kit

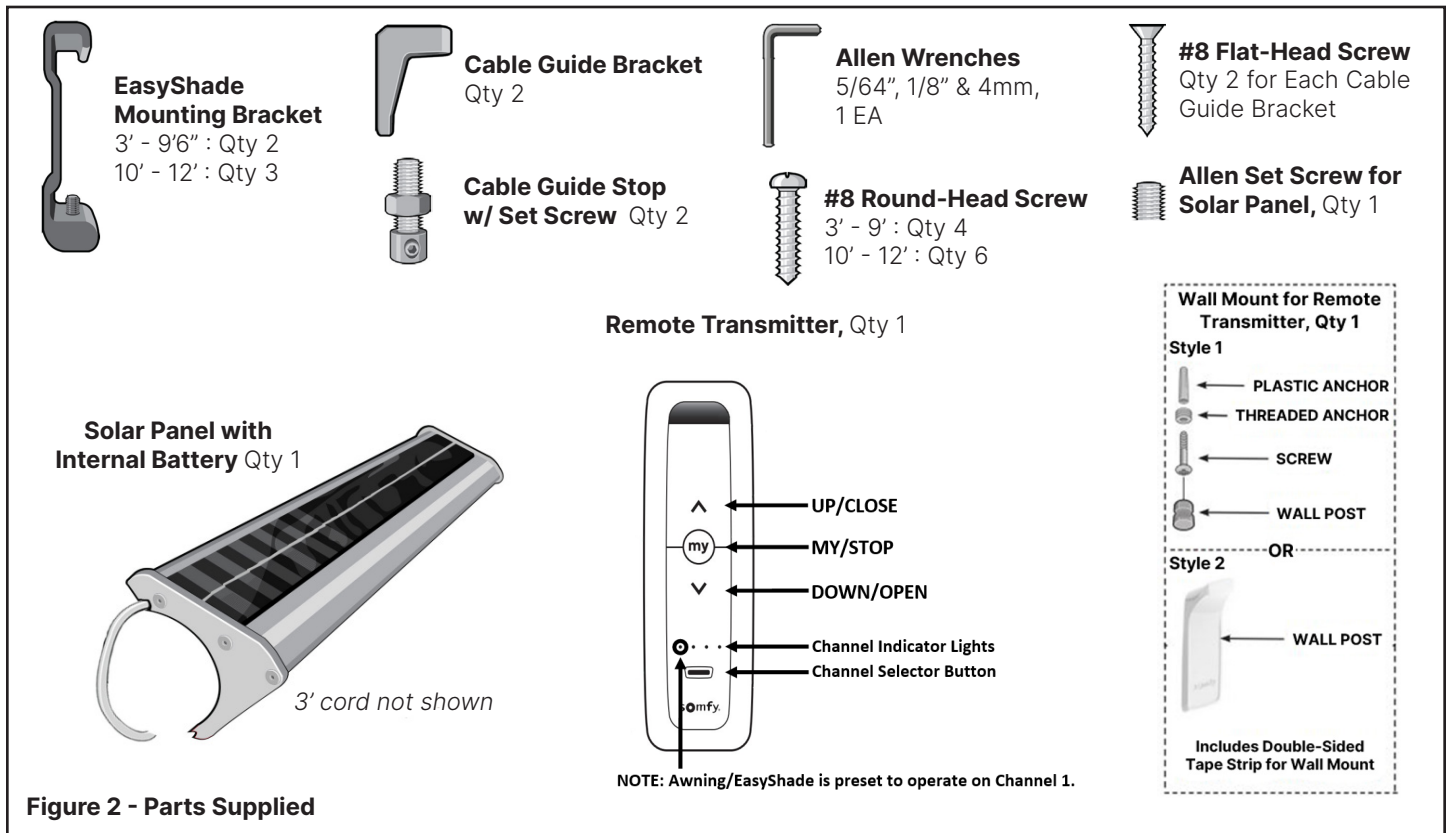

Figure 2 - Parts Supplied

INSTALLATION

Solar Panel and Battery

Your Solar-Powered EasyShade can be used right away.

It is recommended the solar panel be placed in the sun during the installation process to begin the battery recharging process.

If you are not installing right away, place the solar panel in the sun for a day to fully charge the battery.

Attach Solar Panel to EasyShade Housing

The solar panel/battery assembly must be attached to the EasyShade housing before the EasyShade is mounted into the EasyShade mounting brackets (see **Figure 3**).

1. Connect the power cord between the motor and the solar panel. The connectors are keyed to ensure proper alignment of pins in the cable connectors. Secure the ends together using the screw locking mechanism on the connectors (see **Figure 3**).

Note: The LED indicator light on the left end of the solar panel may begin a "heartbeat" blink (one blink every two seconds), indicating the system is operating as expected.

2. Attach the solar panel to the EasyShade housing.

Note: When positioning the solar panel on the housing, route the power cable (connected to the motor) behind the housing. Move the solar panel far enough away to remove slack in the power cable. Total length of the combined cable is about four feet. For narrow EasyShades, excess cable can be tucked behind the housing.

2a) The bottom edge of the solar panel hooks under the front of the fabric panel opening of the EasyShade housing (see **Figure 3**).

2b) The top of the solar panel snaps firmly over the top front edge of the housing (see **Figure 3**).

3. Use the 4mm Allen wrench (supplied) to secure the solar panel to the EasyShade housing by inserting and tightening the provided Allen set screw under the bottom edge of the solar panel, then tighten.

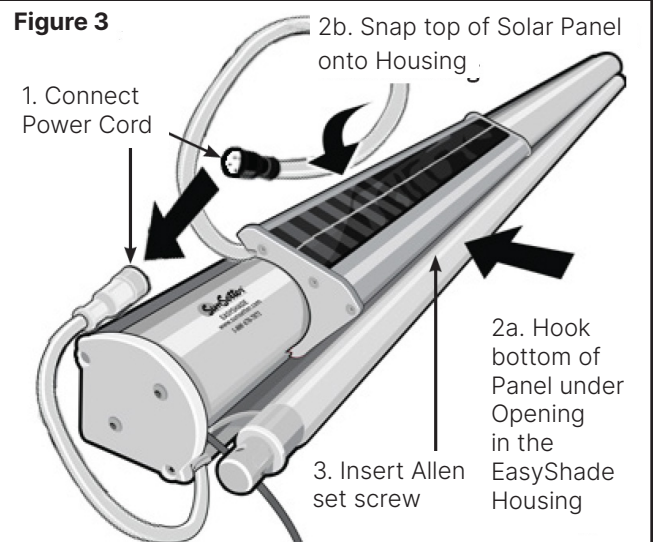

Mount EasyShade Housing to House

4. Determine the desired locations for the EasyShade mounting brackets, making sure they are plumb and level. Mark the two hole locations with a pencil, for the bracket. Drill holes with a 1/8" bit, approximately 1-1/2" deep, at both hole locations. Repeat for the EasyShade mounting bracket on the other side, and the center mounting location on 10' to 12' models.

Install Mounting Brackets - Vertical

5. For mounting on a wall (vertical surface), secure each bracket with two #8 x 1-1/2" round-head screws. Note the orientation of the bracket; the end with the set screw should be at the bottom (see **Figure 4**).

Note: Aluminum housing and cable brackets need to be mounted on the same vertical surface. If mounted to siding, it may be necessary to shim the brackets to create a flat mounting surface.

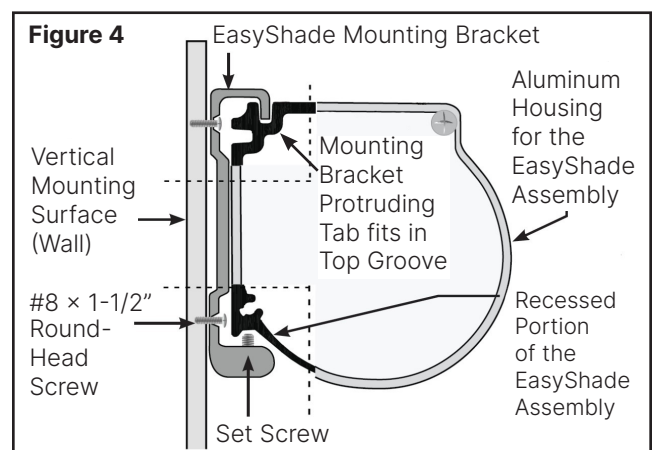

Install Mounting Brackets - Horizontal

- For mounting on an underside structure (horizontal surface), secure each bracket with two #8 x 1-1/2" round-head screws. **Note the orientation of the bracket;** the end with the set screw should face toward you as you face your mounting location (see **Figure 5**).

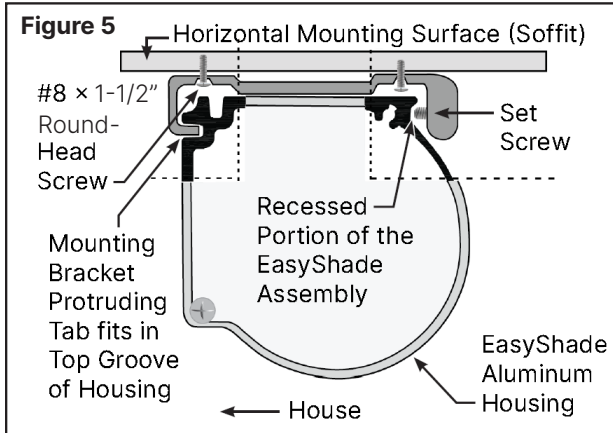

Install EasyShade into Brackets

- With your helper, lift the EasyShade assembly up to the installed mounting brackets and insert the top groove of the EasyShade assembly onto the protruding tab of the EasyShade mounting brackets (see **Figures 4 and 5**). While maintaining upward pressure to keep the top groove of the EasyShade assembly on the tab of the mounting brackets, press the EasyShade assembly toward the mounting bracket and be sure the set screw is aligned in the recessed area of the EasyShade assembly (see **Figure 6**).

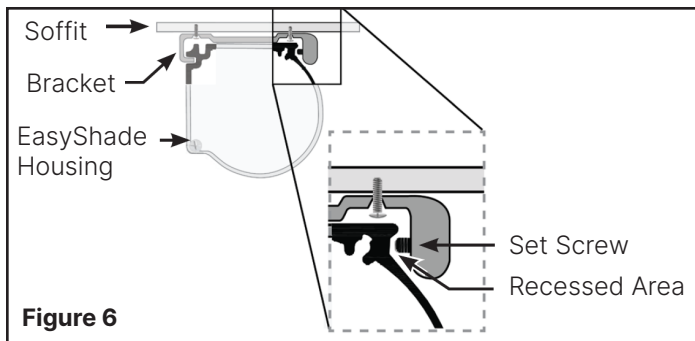

- Using the supplied 1/8" Allen wrench, tighten the set screw in each mounting bracket until the EasyShade assembly is secure (see **Figure 7**).

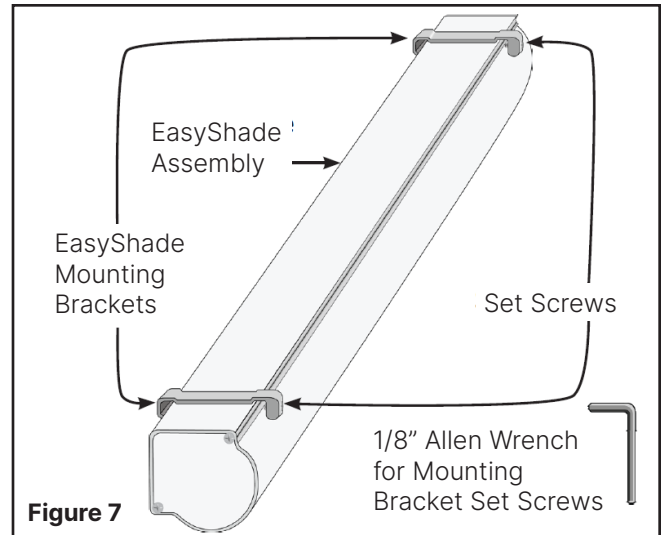

Note: The Up and Down stop limits on the EasyShade motor were set at the factory prior to shipment. The Down stop limit was set for a 36" (3') extension. This will allow for completion of the installation process.

- Extend your EasyShade using the **DOWN** button on your remote (see **Figure 8**). Once you have extended the EasyShade, **unplug the motor power cord from the solar panel cord**.

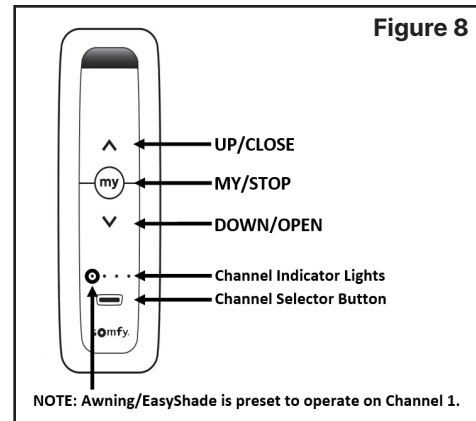

Note: If the EasyShade does not respond when you press the **DOWN** button on the remote, check to see if the first channel selector light on the remote blinks on and off when you press the **DOWN** button (see **Figure 9**). If one of the other channel lights comes on, press the channel selector button until you have switched to the first channel (see **Figure 9**).

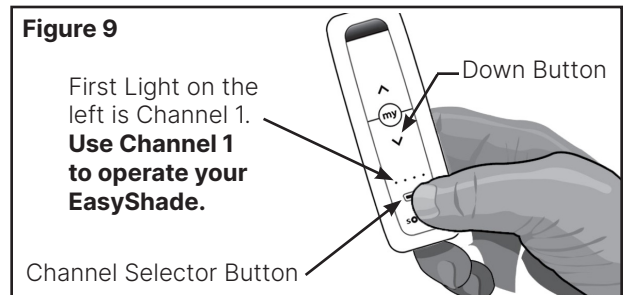

Install Cable Guide Brackets and Cables

CAUTION: The installation procedure for the Solar-Powered EasyShade includes the use of cable guides to stabilize the extended solar screen fabric panel during normal use. If your application does not permit the installation of the necessary cable guides, or you do not plan to install them, you must use additional care to prevent damage to your product. While we do not recommend installing the Solar-Powered EasyShade without the supplied cable guides, some customers may determine that their application does not have a vertical surface to install the supplied cable guides as instructed.

10. Unroll the vinyl coated guide cables located at each end of the aluminum housing assembly, and allow them to hang flat against the mounting surface (see **Figure 10**).

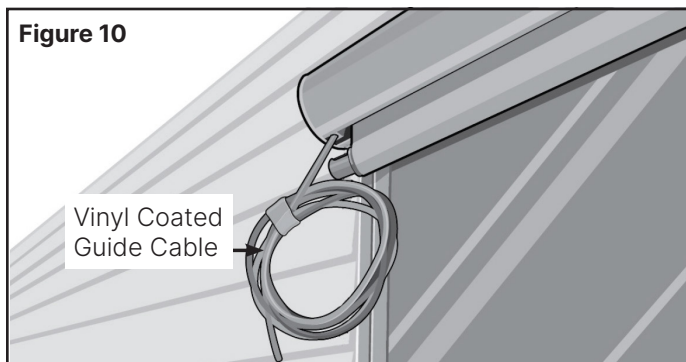

11. Insert the vinyl coated guide cable through the cable guide holes at each end of the aluminum leading bar at the bottom of the solar screen fabric panel (see **Figure 11**).

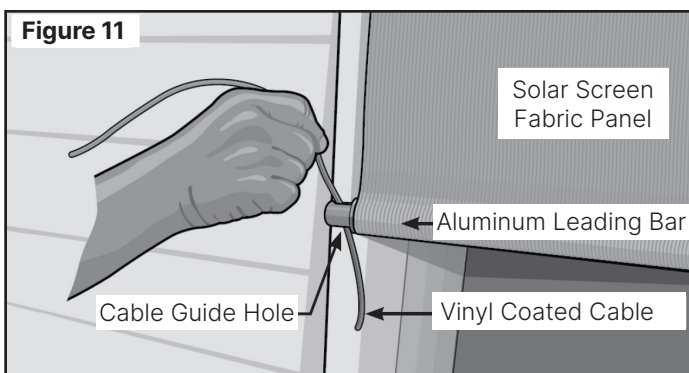

12. Determine how far down your EasyShade will be extended (this is limited to the length of the vinyl coated cable, but you can not exceed 84" (7') from the bottom of the EasyShade housing). **Mark a horizontal line** on the wall where you would like the EasyShade to stop when fully extended, aligned with each end of the EasyShade housing assembly (see **Figure 12**).

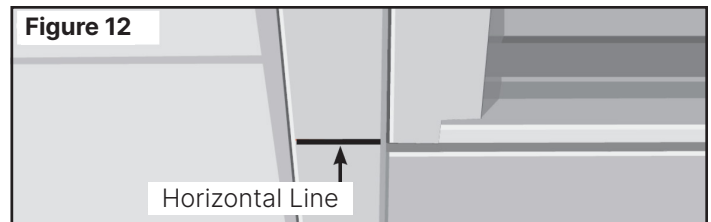

13. Using the vinyl coated cable as a guide, ensure the cable is straight and plumb (using a level) and mark a vertical line (see **Figure 13**) where it crosses the horizontal line made in **Step 12**. Cable guide brackets must be mounted on the same vertical plane as the EasyShade housing.

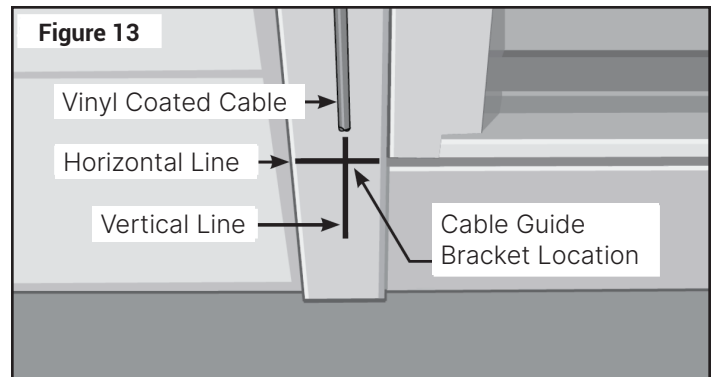

14. Locate the cable guide brackets and cable guide stops in your hardware package.
15. Align the top of the cable guide brackets below the horizontal line and centered on the vertical lines as shown in **Figure 14**. Ensure the bracket is plumb and on the same vertical plane as the aluminum housing above, then mark both screw hole locations. Remove the bracket and pre-drill both screw hole locations with a 1/8" drill bit. Repeat for the other side of the EasyShade.

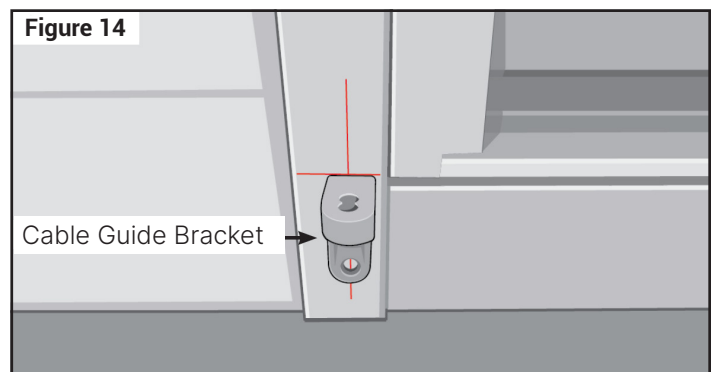

16. Place the cable guide bracket over the pre-drilled holes and secure in place with the #8 x 1-1/2" flat-head screws.

17. Place the lower end of one of the vinyl coated cables through the hole in the cable guide bracket you just installed. From the bottom, slide one of the cable guide stops onto the vinyl coated cable and secure in place with the supplied 5/64" Allen wrench. Repeat for the other side of the EasyShade (see **Figure 15**).

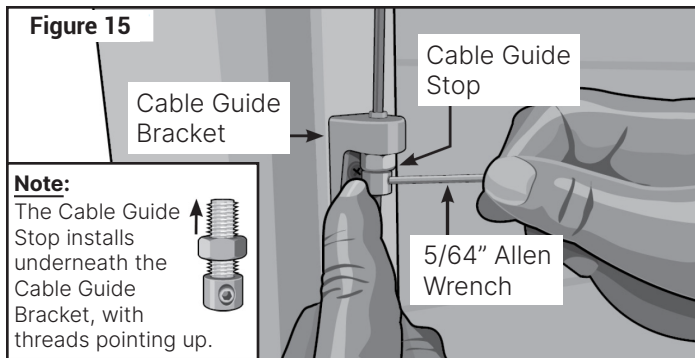

18. Ensure the vinyl coated cables are tight. Adjust cable tension by turning the cable guide stop nut counter clockwise, using a 7/16" open-end wrench (see **Figure 16**).

Note: Do not overtighten the cable.

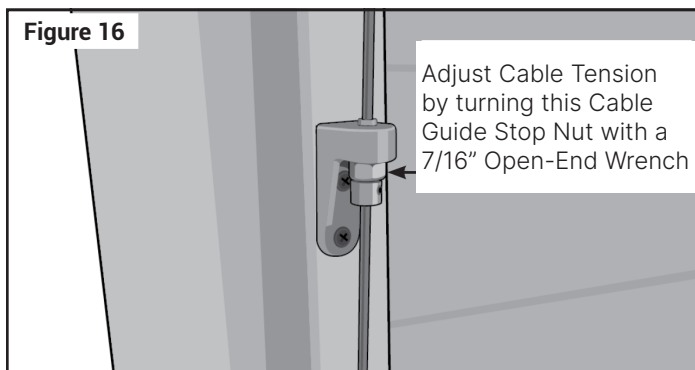

19. If desired, trim off excess vinyl coated cable extending from the bottom of the cable guide stops using a wire cutter (see **Figure 17**).

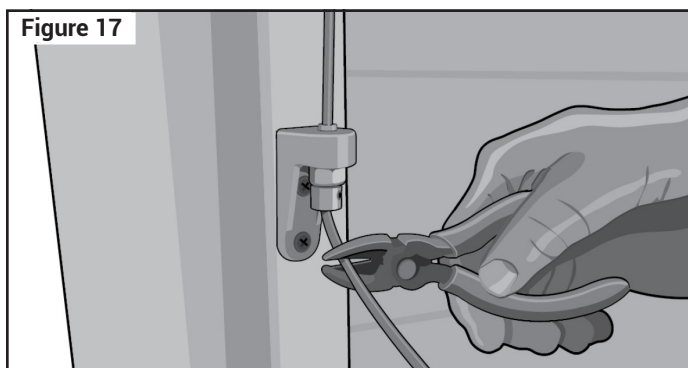

Adjust Lower Stop Limit

Note: The solar screen fabric is preset to stop 36" (3') from the housing. This position can be changed to lower the solar screen fabric as much as 84" (7') from the housing.

20. Plug in the motor.

Press and release the **UP** button on your remote to retract the EasyShade (see **Figure 8**).

21. Press and release the **DOWN** button on your remote to extend the EasyShade to the current "factory setting" (see **Figure 8**).

Let the EasyShade stop on its own.

22. Press and hold the **UP** and **DOWN** buttons on the remote simultaneously, until the EasyShade jogs or moves, then release the buttons (see **Figure 8**).

Note: The EasyShade is temporarily in Programming mode. The **UP** or **DOWN** buttons on the remote must be pressed and held to reposition the EasyShade. When either button is released, the EasyShade will stop moving.

23. Press the **DOWN** or **UP** buttons individually to adjust the new Down stop limit to the position marked in **Step 12** (see **Figure 12**).

CAUTION: Do not let the EasyShade extend more than 84" (7') from the housing (see **Figure 18**).

24. Press and hold the **MY** button on the remote until the EasyShade jogs, then release. Your new **Down** limit position is set and Programming mode ends. The **UP** and **DOWN** buttons now return to work in "one-touch" User mode.

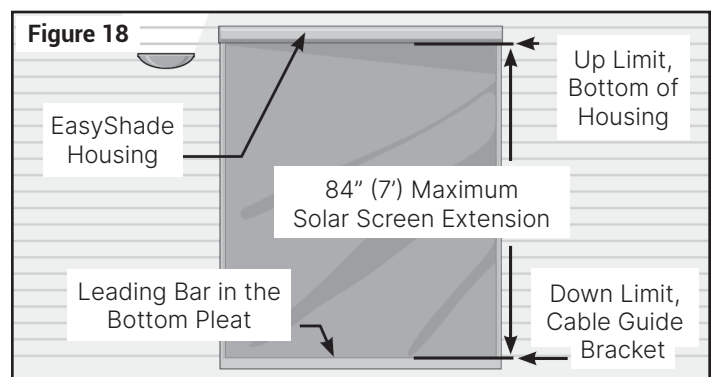

OPERATION

Operating the EasyShade

25. Test the operation of your EasyShade by using the **UP** and **DOWN** buttons on the remote.
 - a. Press and release the **UP** button. The EasyShade will roll up into the EasyShade housing and stop on its own. The **Up** stop limit should stop the EasyShade automatically, before the leading bar at the bottom of the solar screen fabric reaches the housing. See **Appendix A** to adjust this stop limit.
 - b. Press and release the **DOWN** button. The EasyShade will unroll from the EasyShade housing and stop on its own. The **Down** stop limit should stop the EasyShade automatically, before the leading bar at the bottom of the solar screen fabric reaches the physical limit of the cable guide bracket. See **Appendix A** to adjust this stop limit.
26. A wall mount kit has been provided for the remote (see **Figure 2**). Position the wall mount in a safe location, protected from weather.

CAUTION: Do not leave your EasyShade extended during windy conditions, as the uncontrolled movement of the extended EasyShade solar screen fabric panel could cause damage to the product and surrounding items. Simply retract the EasyShade by pressing the UP button on the remote.

CAUTION: Do not permit the hand-held remote to get wet as this can affect its proper operation. It is recommended to keep the remote indoors when the EasyShade is not in use or if rain is expected.

CAUTION: The installation procedure for the EasyShade includes the use of cable guides to stabilize the extended solar screen fabric panel during normal use. If your application does not permit the installation of the necessary cable guides, or you do not plan to install them, you must use additional care to prevent damage to your product. While we do not recommend installing the EasyShade without the supplied cable guides, some customers may determine that their application does not have a vertical surface to install the supplied cable guides as instructed.

“Congratulations, your installation is complete.”

Remote Transmitters are Unique

Each remote transmitter and each channel of each remote transmitter (see **Figure 19**) has its own unique ID code. Each Solar-Powered EasyShade is programmed to receive a signal from a unique remote. A remote can only communicate with a motor if the motor has been specifically programmed to accept signals from that specific remote.

Each Solar-Powered EasyShade is packaged with a remote programmed to control that specific EasyShade. It is recommended to use **channel 1** (see **Figure 19**), the first light from the left, to control the EasyShade.

If you own more than one Solar-Powered or Motorized EasyShade, keep the remote with the EasyShade for which it was programmed.

To control multiple EasyShades with one or more remotes or channels, see **Appendix C**.

Figure 19

Each light represents a separate channel with its own unique ID, which operates as a unique remote transmitter.

Use **channel 1** to operate your EasyShade.

Channel 1 is the first light on the left.

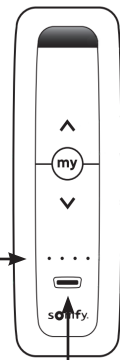

Channel Selector Button.

Press this button and the selected Channel blinks.

Press this button while the selected Channel blinks, and the next Channel is selected.

Solar Panel and Battery

Your Solar-Powered EasyShade is powered by a solar panel with a replaceable battery. To charge the battery, the solar panel must be exposed to at least 12 hours of sunlight. The EasyShade can operate several times on a full, single charge. The number of operations will vary depending on the size of the unit. For example, a 7' Solar-Powered EasyShade will open and close over 40 times on a full charge, in perfect conditions.

LED Indicator Blink Codes

Your solar panel will have an LED indicator light on the left end (see **Figure 20**). This light will blink at different intervals to communicate what the system is experiencing.

See chart below for specific blink codes.

Note: The LED indicator light reacts to solar charging only. If using the optional Solar Battery Charger accessory (sold separately), the light will not respond.

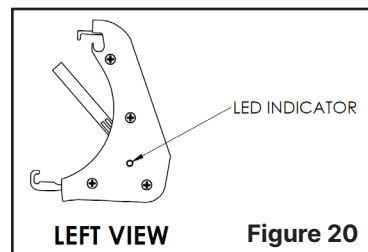

Description	Blink Count	Gap Time (Sec.)
Heartbeat (System is charged and ready for use)	1	2
Battery is charging (Shade can be operated while solar charging)	2	2
Battery Low (Motor drive disabled)	3	2
Outside of Charging Temperature Range – Charging disabled (Charging temp. range: 32°F to 158°F)	4	2
Outside of Running Temperature Range – Motor disabled (Running temp. range: -4°F to 158°F)	5	2
Unknown Fault	6	2
No Blink or Solid on = system fault or extremely low battery		

Optional Items (Sold Separately)

If your EasyShade's mounting location does not receive enough sunlight to consistently charge the battery, the following optional items can be purchased from SunSetter Customer Service at 800-670-7071.

- If needed, the solar panel can be mounted in another location using the optional Remote Wall Bracket (see **Figure 21**) and 6' extension cord (see **Figure 22**).

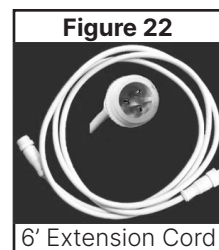
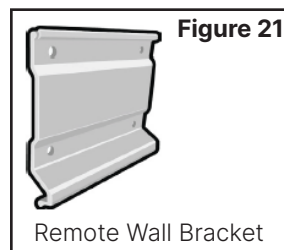

- If needed, the solar battery can be charged using the optional Solar Battery Charger accessory (see **Figure 23**). The Charger acts as an adapter, allowing the solar panel/battery assembly to be plugged into an AC wall outlet.

Note: The LED indicator light reacts to solar charging only. If using the Solar Battery Charger accessory, the light will not respond.

It is not recommended to use the Solar Battery Charger for longer than 3 hours.

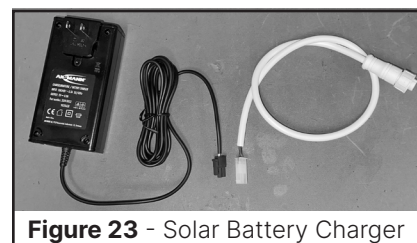

CARE AND MAINTENANCE

Fabric

It is recommended to retract the EasyShade into its maintenance-free, aluminum housing when not in use to keep it clean and protected from dirt and cobwebs.

If needed, use a soft brush to remove dirt and cobwebs. If more cleaning is needed, scrub gently using neutral soap or mild detergent and water, then rinse off with clean water. Never use abrasive or solvent based cleaners. Allow the fabric to fully dry before rolling it back into the aluminum housing.

If you must close the EasyShade while the fabric is wet, we recommend opening the EasyShade the next sunny day to allow the fabric to dry completely to prevent mildew from forming. The fabric itself is mildew-resistant, however mildew can form on dirt, pollen, etc. that may be present on the fabric.

Wet fabric should not be retracted into the aluminum housing during freezing conditions. If the fabric becomes frozen in the aluminum housing, you must allow the unit to completely thaw before extending the fabric.

Solar Panel/Battery Assembly

The solar panel area must be kept clear of debris in order to properly charge the battery.

The solar battery has an expected lifespan of 5 years and will eventually need to be replaced. Replacement solar batteries can be purchased from SunSetter Customer Service at 800-670-7071.

Winterizing the EasyShade

All SunSetter EasyShades are outdoor products that can withstand freezing and wintry conditions. Just retract the fabric into its protective aluminum housing and let the sun warm your house, helping you save on heating costs.

The operating temperature range of the solar panel/battery is -4°F to 158°F, and the charging temperature range is 32°F to 158°F. For areas that drop below 32°F frequently during winter, an optional Solar Battery Charger accessory is available for purchase. The Charger acts as an adapter, allowing the solar panel/battery assembly to be plugged into an AC wall outlet.

Note: If the fabric gets wet, it can freeze inside the housing and fail to extend until the fabric thaws out.

FAQ - FREQUENTLY ASKED QUESTIONS

1: What type of motor is used?

The Solar-Powered EasyShade uses a Somfy 12V motor with a multi-channel remote transmitter.

2: Does the solar panel have to face the sun to absorb energy?

It does not have to directly face the sun. The closer the panel faces the sun, the quicker the battery recharges.

Note: For shadier areas, a Remote Wall Bracket and 6' extension cord are available for purchase. SunSetter also offers a Solar Battery Charger accessory, which allows the solar panel/battery assembly to be plugged into an AC wall outlet. These optional items are available for purchase through SunSetter Customer Service at 800-670-7071.

3: How much time is required to fully charge the solar powered battery?

In perfect conditions, about 12 hours of sunlight exposure are needed to fully charge the solar battery.

Note: The Solar-Powered EasyShade can operate on a partial charge.

4: How many times can the Solar-Powered EasyShade operate on a full charge?

The Solar-Powered EasyShade can open and close several times on a full, single charge. The number of operations will vary depending on the size of the unit. For example, a 7' Solar-Powered EasyShade will open and close over 40 times on a full charge, in perfect conditions.

5: Can I operate the Solar-Powered EasyShade on cloudy days or in the dark?

Yes, provided that the battery has been charged by the solar panel.

For an indication of the battery's charge status, please check the LED indicator light on the left end of the solar panel (see LED Indicator Blink Codes chart **page 10** for details).

7: If it's rainy and/or cloudy for multiple days in a row will my Solar-Powered EasyShade operate?

Yes, provided that the battery has been charged by the solar panel.

For an indication of the battery's charge status, please check the LED indicator light on the left end of the solar panel (see LED Indicator Blink Codes chart **page 10** for details).

8: Is there a battery back up?

No. The unit operates on stored battery power, not directly from the solar panel. However, SunSetter now offers a Solar Battery Charger accessory, which allows the solar panel/battery assembly to be plugged into an AC wall outlet. This optional item is available for purchase through SunSetter Customer Service at 800-670-7071.

9: Is there a manual override?

No.

10: Can the solar panel be left out in the winter?

Yes, the Solar-Powered EasyShade is an outdoor product that can withstand freezing and wintry conditions. See Care and Maintenance section on **page 11** for winterization information.

11: Can the solar panel get wet?

Yes. The Solar-Powered EasyShade is an outdoor product and can withstand rain and snow.

13: What type of battery is used?

Somfy rechargeable 12V Nickel-Metal Hydride.

14: What is the expected life span of the battery?

The battery is warranted for five (5) years not to fail under normal conditions if maintained, operated, used, and stored in accordance with the instructions contained with the product.

15: What is the expected life span of the solar panel?

The solar panel is warranted for five (5) years not to fail under normal conditions if maintained, operated, used, and stored in accordance with the instructions contained with the product.

16: Where can I purchase a replacement solar panel and/or battery?

Replacement solar panels and batteries can be purchased through Customer Service at 800-670-7071.

TROUBLESHOOTING

Problem with Installation	Solution
<p>The solar panel needs more sun to fully charge the battery.</p>	<ul style="list-style-type: none"> • The solar panel/battery assembly can be mounted in a sunnier area using the optional Remote Wall Bracket and 6' extension cord. • The solar panel/battery assembly can be temporarily plugged into an AC wall outlet using the optional Solar Battery Charger accessory. <p>These optional items are available for purchase through SunSetter Customer Service at 800-670-7071.</p>
<p>After installation is complete, my Solar-Powered EasyShade will not function.</p> <p>Note: Remote should be set to channel 1, the first light on the left side of the remote.</p>	<ol style="list-style-type: none"> 1. Use the remote that came with this Solar-Powered EasyShade. Each remote is uniquely different. 2. The remote should be set to work on channel 1. Press the UP or DOWN button on the remote. The first channel indicator light from the left should blink. If not, move to the correct channel by pressing the channel select button. See Appendix C for more information. 3. The battery in the solar panel was originally shipped with enough charge to run the Solar-Powered EasyShade. Expose the solar panel to sun for a full day to ensure enough charge exists in the battery to run the EasyShade. 4. Visually inspect the power cord connecting the motor to the solar panel for possible damage. 5. Disconnect the power cord connector, between the motor and solar panel. Visually inspect the connector pins, ensuring none are bent or broken. Connect the two cord sections, ensuring the pins line up properly and the connector screws together tightly. 6. Listen to the motor. Press the UP or DOWN buttons on the remote and listen for the sound of the motor turning. <ol style="list-style-type: none"> a. If the motor turns, the problem could be mechanical with the solar screen fabric. The motor may turn, but the solar screen fabric may be stuck inside the housing. Try tugging on the leading bar in the bottom pleat of the solar screen, and see if it unrolls from inside of the EasyShade housing. b. If the motor does not turn, the problem could be related to the remote. Go to Step 7. 7. Perform self test on the remote: <ol style="list-style-type: none"> a. One at a time, press and hold the UP or DOWN buttons for 5 to 10 seconds. If the LED light blinks for at least 5 seconds, the remote passes self-test. b. If the LED does not blink, remove and replace the battery. To replace the battery, see the battery replacement instructions under "Problem with Operation", on Page 14. c. If the remote got wet, it may need to be replaced. 8. In extreme cold conditions, verify the EasyShade solar screen fabric is not "frozen" inside the housing. A light tug on the leading bar in the bottom pleat of the solar screen may overcome slight freezing conditions.

TROUBLESHOOTING

Problem with Appearance	Solution
Fabric rolls up unevenly or pulls to one side when the Solar-Powered EasyShade is being closed.	<ol style="list-style-type: none"> 1. Check the aluminum housing to ensure it is mounted level on the mounting surface. 2. It is necessary to have the guiding cables completely plumb, up and down. Both the aluminum housing and the cable brackets must be installed on the same vertical surface or plane, in order for the fabric to open and close smoothly and evenly. Please check to ensure the guiding cable is plumb front to back and left to right. You might need to move the cable brackets, or shim them, to ensure they are on the same vertical plane.
Short lines appear in the solar screen fabric.	Very slight lines in the fabric might be noticed near the top of the solar screen. These are caused by clips required to secure the solar screen fabric to the internal roller bar. This is normal and should diminish over time, under warm conditions. This might be more pronounced under cool conditions.

Problem with Operation	Solution
Remote fails to lower or raise the EasyShade. (Remote should be set to channel 1 , see Figure 29)	<ol style="list-style-type: none"> 1. Test the remote for proper operation; press each button on the front of the remote, holding for 5 to 10 seconds. The LED light on the remote should blink for at least 5 seconds. If this fails, replace the remote's battery (3V Lithium CR2032). 2. Solar panel battery might not have enough charge to run the motor. Ensure the solar panel has one day in the sun to recharge the battery.
Delayed response (half second) to UP or DOWN command.	The solar panel's battery charge is low. Exposure to sun will recharge the solar panel's battery.
Must press DOWN button three times before EasyShade responds.	The solar panel's battery charge is low. Exposure to sun will recharge the solar panel's battery.
EasyShade opens 1 inch, then stops.	The solar panel's battery charge is low. Exposure to sun will recharge the solar panel's battery.
Motor will not respond to any command.	The solar panel's battery charge might be low, causing motor to enter "sleep" mode. Exposure to sun for a full day will recharge the battery.
The red light on the remote does not come on when I press the button. How to replace remote's battery.	<ol style="list-style-type: none"> 1. Remove and replace the remote's battery (3V Lithium CR2032). <ol style="list-style-type: none"> a. Remove the small Phillips screw on the back of the remote, b. Remove back cover, c. Replace the old battery (be sure to note the battery orientation), d. Reinstall the cover with the Phillips screw. 2. If the remote got wet, <ol style="list-style-type: none"> a. Remove the back cover to allow it to dry out completely, b. Once completely dry, replace the back cover and try again. <p>Note: An All Weather Remote is available for purchase.</p>
My Solar EasyShade retracts but will not fully close into the aluminum housing.	<p>Adjust the Up limit on your EasyShade motor. See Appendix A, Adjusting the Up and Down Position Limits of the Motor.</p> <p>If the solar screen fabric has been replaced, new Up and Down position limits might need to be set for the motor. If so, see Appendix B, Programming the EasyShade's Stop Position Settings.</p>

TROUBLESHOOTING

Problem with Operation	Solution
My EasyShade retracts but will not fully close into the aluminum housing.	Adjust the Up limit on your EasyShade motor. See Appendix A , Adjusting the Up and Down Position Limits of the Motor. If the solar screen fabric has been replaced, new Up and Down position limits might need to be set for the motor. If so, see Appendix B , Programming the EasyShade's Stop Position Settings.
Fabric is stuck inside the aluminum housing	In extreme cold conditions, verify the solar screen fabric is not "frozen" inside the housing. A light tug on the leading bar in the bottom pleat of the solar screen can overcome slight freezing conditions.
My EasyShade rolls out and keeps going until the solar screen begins to sag.	If the motor stops on its own at a programmed stop position, then adjust the Down position stop limit according to instructions in Appendix A . If the motor will not stop on its own, and you must press the MY button to stop the motor, then set new Up and Down stop position limits according to instructions in Appendix B .
Can I program multiple EasyShades to operate on one master remote?	Yes. Each channel on the remote can control one or more EasyShades. See Appendix C , Programming Instructions for Multi-Channel Remote Transmitter.
Can I use more than one remote to control one EasyShade?	Yes. The EasyShade motor can be programmed to respond to multiple remotes. Additional remotes can be purchased through SunSetter Customer Service at 800-670-7071. See Appendix B , Appendix C , or follow the instructions that come with additional remote(s).
What if I lose my remote, or it becomes damaged? Can the original remote be replaced? Do I need to reprogram my motor?	The original remote shipped with your Solar-Powered EasyShade can be easily replaced. Please call Customer Service at 800-670-7071 to purchase a replacement. The programmed Up and Down stop limits are permanently stored in the motor. These settings do not need to be reset or changed due the addition or removal of remotes. Instructions for replacing the remote are included with the replacement remote.
The EasyShade only operates while the UP or DOWN button is being pressed.	The motor is in probably in Programming mode. Complete the programming procedure by following the Additional Motor Troubleshooting steps on page 16 . If the problem persists, please call SunSetter Customer Service for assistance at 800-670-7071.
How to self test the remote:	<ol style="list-style-type: none"> 1. Press each button (UP, DOWN, MY) on the front of the remote, one at a time. 2. Hold each button for 5 to 10 seconds. 3. LED light should blink for at least 5 seconds, then stop blinking. 4. If Steps 1 - 3 work, the remote is good. 5. If this fails, replace the remote's battery (3V Lithium CR2032).

TROUBLESHOOTING

Additional Motor Troubleshooting

Problem with Motor	Solution	
<p>EasyShade does not respond to remote. <i>(First, verify that remote is on channel 1 and has a good battery that is inserted correctly, and verify solar panel has had adequate sun exposure and time to charge)</i></p> <p>OR</p> <p>EasyShade only runs while holding the UP or DOWN button on the remote.</p> <p>OR</p> <p>Appendix B failed to complete properly.</p>	<ol style="list-style-type: none"> 1. Unplug motor. 2. Wait two seconds. 3. Plug in motor. 4. If motor jogs when plugged in, go to Section A. 5. If motor does not jog when plugged in, go to Section B. 	
	Section A	Section B
	<ol style="list-style-type: none"> 1. Press and hold the UP and DOWN buttons together, on the remote. 2. Hold until motor jogs or moves. 3. Press and hold the PROGRAMMING button. 4. Hold until motor jogs or moves a little bit. 5. Test for normal operation. 	<ol style="list-style-type: none"> 1. Press and hold the UP and DOWN buttons together, on the remote. 2. Hold until motor jogs or moves. 3. Perform Steps 9 - 18 in Appendix B. 4. Test for normal operation.
	<p>If Section A or B (above) does not fix the problem, then...</p> <p>Perform Steps 1 - 18 in Appendix B, or call Technical Support at 800-670-7071.</p>	

APPENDIX A

Adjusting the Up and Down Stop Position for the Solar-Powered EasyShade

Follow these instructions to change the position where the EasyShade stops. This is for both the Up and the Down stop positions (see Figure 24).

Note: Do not exceed the 84" (7') Down stop position limit as this will cause the fabric panel to roll up backwards in the housing (see Figure 24).

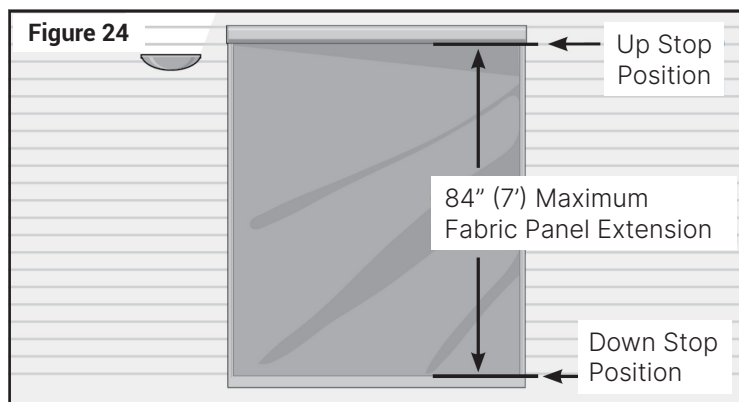

To Change the Up Stop Position:

1. Move the EasyShade to its current Up position (see Figure 25) and let it stop on its own.
2. Press and hold the **UP** and **DOWN** buttons (see Figure 27) simultaneously until the EasyShade jogs or moves, then release.
3. Adjust to a new Up stop position.
4. Press and hold the **MY** button until the EasyShade jogs or moves, then release.
5. Check the new Up position.

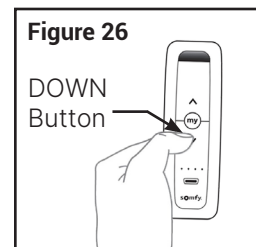
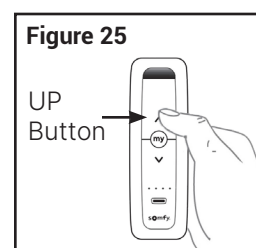

To Change the Down Stop Position:

1. Move the EasyShade to its current Down position (see Figure 26) and let it stop on its own.
2. Press and hold the **UP** and **DOWN** buttons (see Figure 27) simultaneously until the EasyShade jogs or moves, then release.
3. Adjust to a new Down stop position.
4. Press and hold the **MY** button until the EasyShade jogs or moves, then release.
5. Check the new Down position.

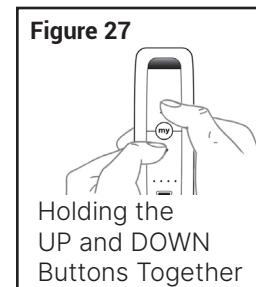

Note: Every EasyShade is programmed to work on channel 1 (see Figure 28) of the specific remote shipped with that EasyShade. For more information, see page 9.

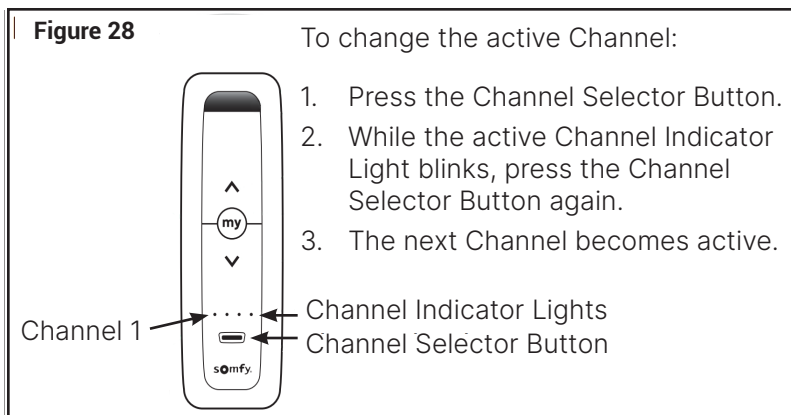

APPENDIX B

Programming the Motor

This procedure describes the actions needed to reset the communication between the motor and the primary remote used to control your Solar-Powered EasyShade.

This procedure programs the EasyShade motor to accept commands from one primary remote.

This procedure overwrites the factory-set Up and Down positions with new Up and Down positions.

Note: To **ONLY** change the Up and Down preset positions, follow the basic procedure in Appendix A.

Tools Needed: A pen or similar pointing device is needed to press and hold the **PROGRAMMING** button.

WARNING: ALL STEPS MUST BE FOLLOWED EXACTLY AND COMPLETELY

Front View

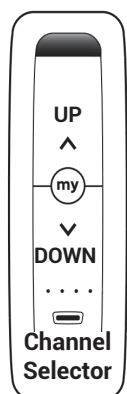

Figure 29

PREPARE MOTOR - See Figures 29 & 30

1. Read these instructions **FIRST**, completely and thoroughly.
2. Disconnect power (at the solar panel connector) for 5 full seconds.
3. Connect power (at the solar panel connector) for 10 full seconds.
4. Disconnect power (at the solar panel connector) for 5 full seconds.
5. Connect power (at the solar panel connector). EasyShade should move then stop on its own.
6. Press and hold the **PROGRAMMING** button for ten seconds, watching for **two separate jogs** back and forth, several seconds apart.
Note: A single jog is a quick two-direction movement of the motor.
7. Press and hold the **UP** and **DOWN** buttons together until your EasyShade jogs.
Note: The EasyShade now moves **ONLY** while holding down the **UP** or **DOWN** button.

SET PROPER DIRECTION OF MOTOR ROTATION

8. Press the **DOWN** button to check the direction of the motor.
The solar screen should roll down from the aluminum housing, from the side closest to the house.
9. If the direction is incorrect, change direction by holding the **MY** button until the motor jogs.
Press the **DOWN** button again to check for the correct direction of the motor rotation.

SET THE UP AND DOWN POSITIONS

10. Move the EasyShade to the desired Up position.
11. Press and hold the **MY** and **DOWN** buttons together, release when the EasyShade begins to move.
12. Press the **MY** button to stop the EasyShade at the desired Down setting.
13. Make desired adjustments to the Down position.
14. Press and hold the **MY** and **UP** buttons together; release them when the EasyShade begins to move up. Let the EasyShade stop on its own at the Up position set in step 10.
Note: If steps 7-14 fail, unplug the power, plug back in, then begin again from step 7.
15. Press and hold the **MY** button, release when the motor jogs. This step stores the Up and Down position limits are set.
16. Press and hold the **PROGRAMMING** button, wait for jog. This exits the Programming mode.
17. Process complete. Test the Up and Down stop position limits.

Rear View



Figure 30

Add/Delete a Control Device (Remote Transmitter)

To **ADD** an additional remote for controlling this particular EasyShade:

1. Press **PROGRAMMING** button on the back of the remote supplied with the EasyShade until the motor jogs.
2. On the additional remote, press the **PROGRAMMING** button until the motor jogs, then release.

To **DELETE** a remote, repeat the two steps listed above; the additional remote is removed.

APPENDIX C

Programming Instructions - Multi-Channel Remote Transmitter

Note: Each EasyShade operates on channel 1 of the remote that came with it. Every channel on every remote is different, but you can mix and match them.

How to use the multi-channel remote transmitter (see Figure 31):

- To identify the currently selected channel, press and release the Channel Selector button once. The currently selected channel indicator light will blink.
- To select the next channel, press and release the Channel Selector button while the channel indicator light blinks. The next channel is selected and that channel indicator light blinks. All 4 lights blinking means channel 5 is selected.

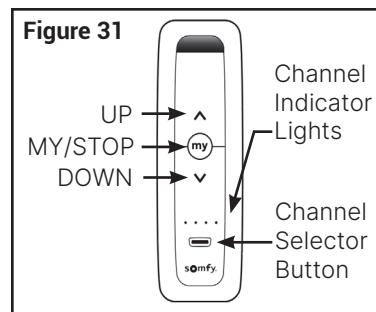

How to program the EasyShade to work with any Channel (see Figures 32, 33 & 34):

One EasyShade can run on any channel (see Figure 32).

Add each channel to the EasyShade, using **STEP 1**, then **STEP 2** in Figure 34.

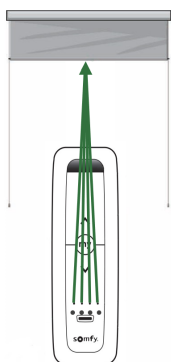

Figure 32

One channel can run multiple EasyShades (see Figure 33).

Add that Channel to each EasyShade, using **STEP 1**, then **STEP 2** in Figure 34.

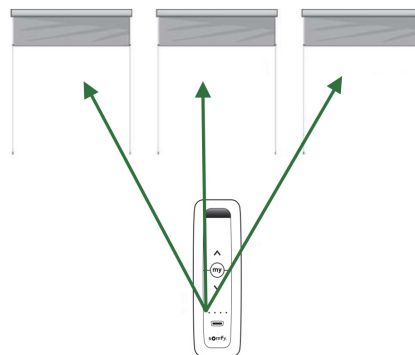
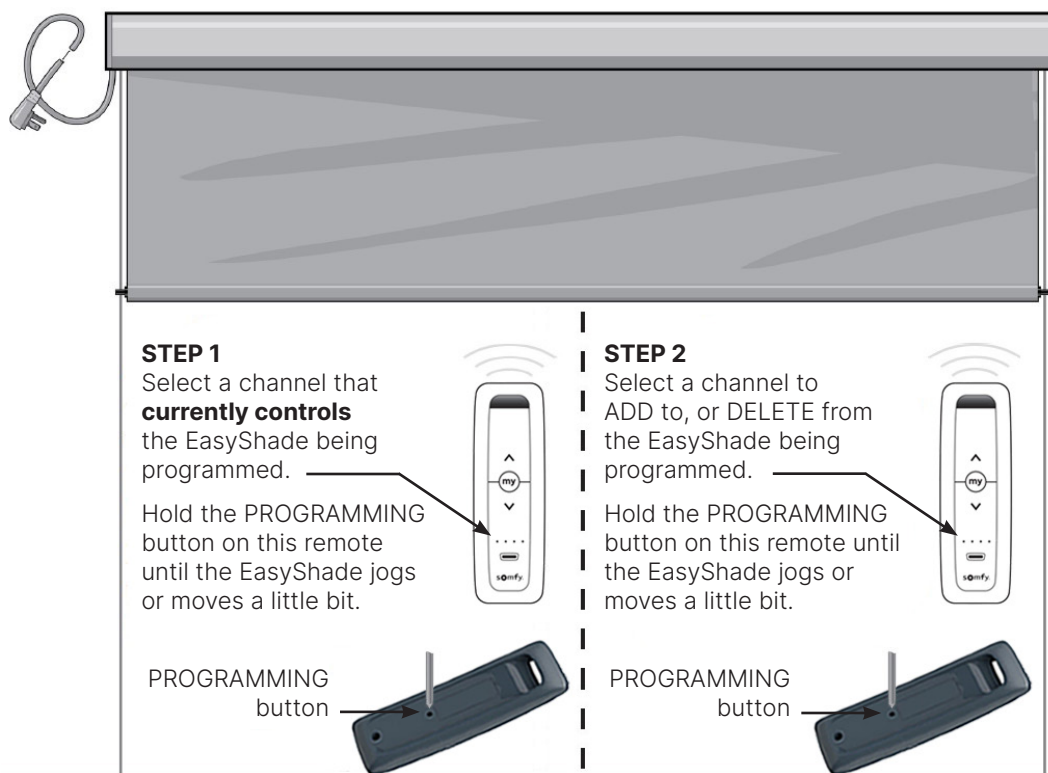

Figure 33

Unwanted channels can be removed from an EasyShade using **STEP 1**, then **STEP 2** in Figure 34.

Figure 34

Note: It is recommended all EasyShades be unplugged from the power source except for the one EasyShade being programmed. This simplifies the process and reduces errors.



5-Year Limited Manufacturer's Warranty for SunSetter EasyShade

A. WHO GIVES THIS WARRANTY?

SunSetter Products LP (hereinafter "SunSetter Products"), 7549 Graber Road, Middleton, WI 53562

B. WHO IS ENTITLED TO THIS WARRANTY?

This Warranty applies only to the original purchaser who paid for the product and may not be assigned or transferred to subsequent owners. This Warranty applies only to products purchased and installed in the US.

C. WHAT ARE THE RESPONSIBILITIES OF SUNSETTER PRODUCTS UNDER THIS WARRANTY?

Subject to the terms and conditions set forth herein, SunSetter Products will furnish replacements for parts found by SunSetter Products to be defective in design, manufacture or assembly, under each specific component or product warranty as set forth below.

D. WHAT ARE THE RESPONSIBILITIES OF THE ORIGINAL PURCHASER UNDER THE WARRANTY?

1. Before any claims may be made under this Warranty, the original purchaser must have paid in full for the product covered under the Warranty, according to the terms and conditions of the pay-plan defined in the original order. **IF THE PURCHASER HAS FAILED TO MAKE FULL PAYMENTS ACCORDING TO THE SPECIFIC PAY PLAN FOR THE PRODUCT, THIS WARRANTY SHALL BE NULLIFIED AND SUNSETTER PRODUCTS SHALL BE RELIEVED FROM ANY RESPONSIBILITY OR LIABILITY UNDER THIS WARRANTY.** The purchaser agrees and acknowledges that this Warranty agreement constitutes an executory contract.
2. The purchaser must use care in installation, maintenance, operation, use, and storage of the product in accordance with the instructions contained with the product. **ANY FAILURE TO INSTALL, MAINTAIN, OPERATE, USE AND STORE THE PRODUCT IN ACCORDANCE WITH THE INSTRUCTIONS CONTAINED WITH THE PRODUCT WILL NULLIFY THIS WARRANTY AND RELIEVE SUNSETTER PRODUCTS FROM ANY RESPONSIBILITY OR LIABILITY UNDER THIS WARRANTY.**

3. Promptly notify SunSetter Products of any claims.
4. The purchaser may be required to provide a photograph of any defective parts. The purchaser may also be required to pay a deposit until the defective parts are returned to SunSetter Products for inspection. The purchaser must obtain a return authorization form from SunSetter Products' customer service department prior to the return of any merchandise and after having received such authorization, return the part or product, freight prepaid, to SunSetter Products.

E. WHAT IS COVERED UNDER THIS WARRANTY?

1. The following components of the EasyShade are covered under this Warranty, subject to the limitations set forth below. **These components have up to five (5) year limited (prorated) warranty**, against manufacturer's defects as outlined below:
 - a. Should the purchaser promptly notify SunSetter Products of such defects within one year (12 months) from the date of the original purchase, the defective component will be replaced at no charge.
 - b. After one year but within the warranty period as listed below for each component from the date of the original purchase, a defective component will be replaced upon the purchaser's payment of the prorated amount based on full retail price of the specific components and the number of months from the date of the original purchase till the claim date as percent of the total number of months during the warranty period.
2. **Covered Components:**
 - i. **STRUCTURAL COMPONENTS AND GEAR MECHANISM OR ELECTRIC MOTOR** (whichever applies to your model) are **warranted for five (5) years** not to fail under normal conditions if maintained, operated, used, and stored in accordance with the instructions contained with the product.
 - ii. **VINYL MESH is warranted for five (5) years** against:
 - a. Excessive fading under normal conditions if maintained, operated, used, and stored in accordance with the instructions contained with the product.

- b. Mildew on vinyl mesh. Mildew will not form on the mesh itself, but may form on dirt and dust that have not been removed from it. The purchaser must clean the vinyl mesh periodically with water and mild soap to prevent dirt from accumulating.
- c. Excessive cracking or peeling under normal conditions if maintained, operated, used, and stored in accordance with the instructions contained with the product.
- iii. **SOLAR PANEL ASSEMBLY** (solar-powered model) is warranted for five (5) years not to fail under normal conditions if maintained, operated, used, and stored in accordance with the instructions contained with the product.
- iv. **BATTERY PACK** (solar-powered model) is warranted for five (5) years not to fail under normal conditions if maintained, operated, used, and stored in accordance with the instructions contained with the product.

- 2. **TO THE EXTENT PERMITTED BY LAW, SUNSETTER PRODUCTS SHALL HAVE NO LIABILITY TO THE PURCHASER OR ANY OTHER PERSON FOR INCIDENTAL, SPECIAL, CONSEQUENTIAL, INDIRECT OR SIMILAR DAMAGES OF ANY KIND OR NATURE WHATSOEVER, WHETHER ARISING OUT OF BREACH OF WARRANTY OR OTHER BREACH OF CONTRACT, NEGLIGENCE OR OTHER TORT, OR OTHERWISE, EVEN IF SUNSETTER PRODUCTS SHALL HAVE BEEN ADVISED OF THE POSSIBILITY OR LIKELIHOOD OF SUCH POTENTIAL LOSS OR DAMAGE. IN NO EVENT SHALL SUNSETTER PRODUCTS BE LIABLE FOR LOSS OF PROFITS AND/OR WAGES.**
- 3. Some states do not allow limitations on how long an implied warranty lasts, or do not allow the exclusion or limitation of incidental or consequential damages, so the above limitations may not apply to you.
- 4. This warranty gives you specific rights, and you may have other rights, which vary from state to state.

F. WHAT IS NOT COVERED UNDER THIS WARRANTY?

- 1. Any failure or damage of the components that results from any intentional or negligent actions by the purchaser or by any other person is not covered by this Warranty.
- 2. It is the responsibility of the purchaser to securely fasten the EasyShade to studs, joists, headers or other structural members. Any failure or damage that results from the EasyShade falling from its installed position is not covered by this Warranty.
- 3. Labor charges connected with installation of replacement parts are not covered by this Warranty.
- 4. Freight expenses to and from SunSetter Products in shipping damaged or replacement parts are not covered by this Warranty and must be paid by the purchaser.

G. GENERAL PROVISIONS AND LIMITATIONS

- 1. **THE WARRANTY GRANTED HEREIN IS THE EXCLUSIVE REMEDY FOR THE PURCHASER. SUNSETTER PRODUCTS MAKES NO OTHER WARRANTIES TO THE PURCHASER, EXPRESS, STATUTORY, IMPLIED OR OTHERWISE AND ALL IMPLIED WARRANTIES, INCLUDING WITHOUT LIMITATIONS, IMPLIED WARRANTIES OF MERCHANTABILITY AND FITNESS FOR A PARTICULAR PURPOSE, ARE HEREBY DISCLAIMED.**

Thank you for choosing SunSetter