



RETRACTABLE AWNINGS

For Technical support visit us at www.sunsetter.com/ownerscorner
or call Toll Free 800-670-7071 • Fax 877-224-4944

CENTER BRACE

INSTALLATION INSTRUCTIONS FOR MODEL 900XT & 1000XT AWNINGS

TOOLS REQUIRED: Electric drill, 1/8" drill bit, 1/4" nut driver or socket, measuring tape, ladder, hammer.

PARTS ENCLOSED: Center Brace, (1) mounting bracket, (2) screws, (2) nylon spacers, (2) large hitch pins, (1) small hitch pin, (1) rubber tip.

The Model 900XT & 1000XT awnings use a Crank Wand to unroll the awning

WARNING: Failure to wear safety glasses or to follow the instructions below can result in PERSONAL INJURY.

WARNING: The gas spring assembly cannot be compressed by hand when not installed on the awning.

Caution: Your mounting bracket for the Center brace must be mounted on the same vertical plane as the awning rail.

Step 1. Open the awning to the fully extended position. Raise the front of the awning to allow clearance for installing the mounting bracket under the awning rail.

Step 2. To install the mounting bracket, mark the center point of the awning rail. Place the mounting bracket flush up against the awning rail with the center of the mounting bracket on the marked location. Mark the two mounting screw locations.

Step 3. Remove the bracket and drill two 1/8" pilot holes in the mounting hole locations that you marked. **Be careful not to damage the fabric with the drill.**

Step 4. Attach the mounting bracket using the two supplied screws with one nylon spacer on each screw as shown in Figure 1. Be certain that the screws are installed straight, if they are crooked the rubber tip of the Center Brace will not seat properly between the nylon spacers.

Step 5. Lower the front of the awning to approximately head height.

Step 6. The installation hole for the Center Brace is already in place in the roller bar on your awning. On the roller bar, locate the round cream-colored sticker that covers the installation hole in the middle of the roller bar. Remove only the one that is for the Center Brace (the roller bar contains the installation holes for every accessory that we offer).

Step 7. Insert the gas spring assembly into the end of the inner brace as shown in figure 2. Position the square end of the gas spring assembly in line with Hole 2 on the inner brace. (see figure 2). Secure them together using the short hitch pin.

Step 8. Assemble the outer brace and the inner brace together using one of the long hitch pins as shown in figure 3. Place a rubber tip over the end of the outer brace as shown in figure 1.

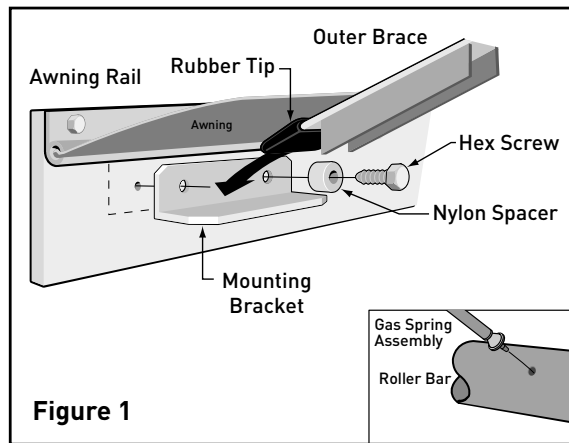

Figure 1

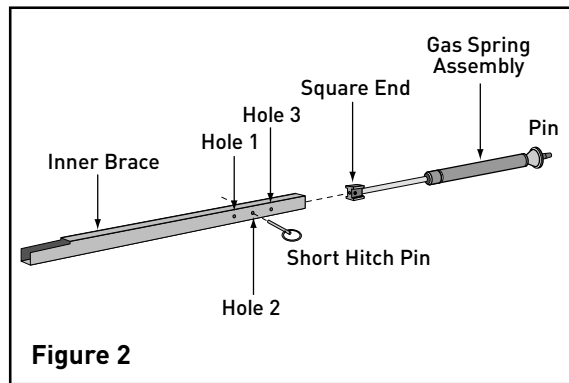

Figure 2

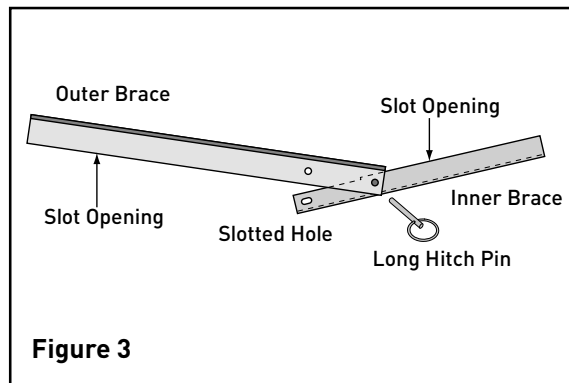

Figure 3

Step 9. Hold the outer brace with the slot opening facing downwards and set the flat end with the rubber tip into the mounting bracket under the awning rail. Make sure the rubber tip is positioned between the installed screws and nylon spacers on the bracket (see Figure 1). The open slot of the outer brace should be facing down and the open slot of the inner brace should be facing up. Failure to position the outer brace and inner brace correctly will result in incorrect operation of the Center Brace

Step 10. While holding the outer brace against the mounting bracket, insert the pin on the gas spring assembly completely into the hole in the roller bar. Using two hands to hold the Center Brace as shown in figure 4, push up on the Center Brace until the inner brace is completely inside the outer brace. Insert a long hitch pin through the hole in the outer brace to secure.

WARNING: Avoid pushing up at the pinch point between the inner brace and outer brace.

WARNING: WHEN INSTALLED, THE BRACE IS UNDER GAS SPRING TENSION. BEFORE REMOVING THE BRACE FROM YOUR AWNING, HOLD THE OUTER BRACE WITH ONE HAND, THEN REMOVE THE LONG HITCH PIN LOCATED THE CLOSEST TO THE HOUSE, AND THEN SLOWLY LOWER THE BRACE DOWN AND AWAY FROM THE ROLLER BAR AND THE HOUSE. FAILURE TO DO SO CAN RESULT IN PERSONAL INJURY.

Step 11. After completing step 10, measure the distance between the edge of the inner brace and the edge of the roller bar (see Figure 5). If less than 1-1/4" simply remove the Center Brace from the awning and move the gas spring assembly to Hole 1 (see Figure 2), then reinstall the Center Brace. If it is more than 2-1/4" simply remove the Center Brace from the awning and move the gas spring assembly to Hole 3 (see Figure 2), then reinstall the Center Brace. This process will not change the distance between the edge of the inner brace and the edge of the roller bar, it will simply set the proper operating range of the gas spring.

WARNING: WHEN USING THE AWNING IN THE RAIN, YOU MUST LOWER ONE ARM TO CREATE ENOUGH DROP SIDEWAYS TO PREVENT RAIN FROM ACCUMULATING ON THE FABRIC. FAILURE TO DO SO CAN RESULT IN PERSONAL INJURY.

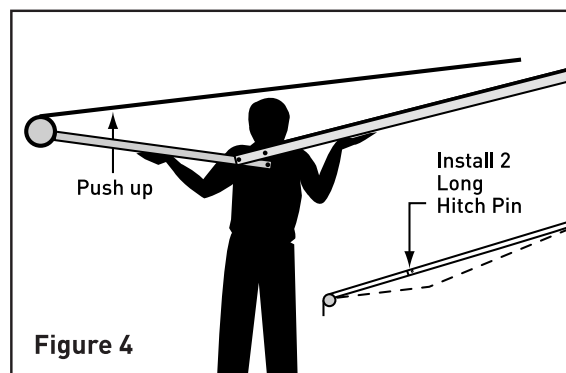

Figure 4

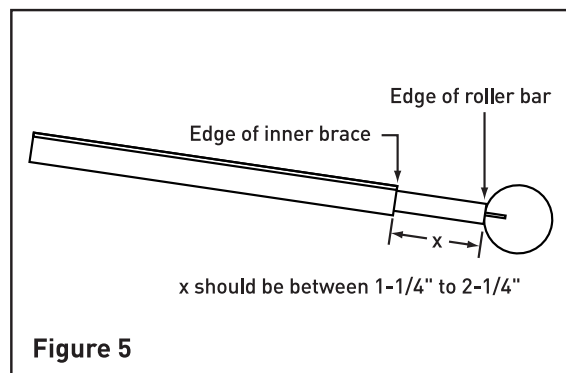

Figure 5