



OWNER'S MANUAL & INSTALLATION INSTRUCTIONS

*Do Not Discard,
Retain for Future Reference*

**VISTA[®] Awnings,
Motorized Awnings**

**Motorized PRO
Awnings**

**Motorized XL and
Motorized PRO XL
Awnings**

**WARNING:
FAILURE TO FOLLOW THESE
INSTRUCTIONS COULD
RESULT IN
PERSONAL INJURY!**

For Technical support visit us at <http://ownerscorner.sunsetter.com>
e-mail at contactus@sunsetter.com or call Toll Free 800-670-7071 • Fax 877-224-4944

READ ME FIRST!

Congratulations! You have just purchased America's #1 Retractable Awning. The SunSetter Lateral Arm Awning will provide you and your family with many years of enjoyment on your deck or patio.

Before you begin installation, take a moment to familiarize yourself with the Awning and your Owner's Manual. You may also find it helpful to view the DVD included with the Awning hardware for a visual walkthrough of the Awning installation. Please check to ensure all of the parts listed on **Page 4** and **5** have been included with your Awning and that you have the correct size, color and model Awning.

Installation of your Awning

When unpacking your Awning, take care to protect the Awning from accidental damage or soiling. Do not drop or drag the Awning on the ground.

Note: When removing the clear protective wrap from the Awning, do not use a knife or box cutter to cut plastic wrap as you could accidentally slice into your Awning Fabric.

Note: Your Awning has been shipped to you fully assembled but it is important to follow this instruction manual to securely fasten the Mounting Brackets to your home and install the Awning.

Please read these instructions completely before installing your SunSetter Awning. Please note, you will need an assistant(s) for installation. Left and Right references are as you face the house. You have been provided with the proper fasteners for mounting to your wall surface (either wood lag screws or masonry bolts).

For the greatest enjoyment of your Lateral Arm Awning, **please mount as high on your wall as possible**, with a **recommended mounting height of 9'**. If your Awning is a motorized model, your electrical cord will allow you 18' to reach your GFI outlet and you will find your Remote Transmitter attached to the cord. It is recommended that you install a protective Cover or Hood on your Awning. If a cover has been purchased with your Awning, install at **Step 15**. If you are installing to a soffit, install the cover at **Step 27**.

Operation of your Awning

Note: If you purchased an 18', 19' or 20' Awning with acrylic fabric, please review the **CAUTION** on **Page 14**, under "Test for Proper Operation" before using your Awning. Your SunSetter Awning, once installed, has the ability to be opened partially or to its full projection to suit your deck or patio design. The pitch of your Awning may be easily adjusted, up or down, from the factory setting based upon your actual mounting height. Please see **Appendix B on Page 23** if you would like to make this adjustment.

Note: Please follow the Care and Maintenance Guidelines on **Pages 16 through 18** for proper use and inclement weather precautions.

Please retain your Owner's Manual and Installation Instructions for future reference regarding operation, care and maintenance, troubleshooting, customer service and warranty information.

Customer Support

Our technical experts are available from **8am - 10pm EST** daily via email at contactus@sunsetter.com, or call us at **800-670-7071** should you require assistance. We also invite you to visit the Owner's Corner website at ownerscorner.sunsetter.com for additional information on your Awning and other SunSetter products.

We know that you will be delighted with your SunSetter Awning and will experience many years of added enjoyment on your deck or patio.

TABLE OF CONTENTS

| | |
|---|------------|
| READ ME FIRST | Page ii |
| TABLE OF CONTENTS | Page iii |
| Awning Installation Instructions | Page 1 |
| Supplied Fasteners/Parts List | Page 4 |
| Additional Parts Supplied - Motorized Only | Page 5 |
| Tools Required | Page 6 |
| Installation Area | Page 6 |
| Wall Mount Installation (Standard Wall Bracket and XL Wall Bracket) | Page 6 |
| Mounting Height for Wall Brackets | Page 6 |
| Wall Bracket Locations | Page 8 |
| Installing Brackets on Wood Frame Walls | Page 8 |
| Installing Brackets on Masonry, Brick, or Concrete Walls | Page 9 |
| Securing the Awning into the Wall Brackets (Awning Weight Chart) | Page 10 |
| Soffit Mount Installation - Mounting Line | Page 11 |
| Soffit Bracket Locations | Page 11 |
| Mounting Brackets into the Soffit | Page 11 |
| Protective Cover Installation - Soffit | Page 12 |
| Securing the Awning into the Soffit Brackets (Awning Weight Chart) | Page 13 |
| Check Your Awning for Proper Operation | Page 13 |
| Test for Proper Operation | Page 14 |
| The Multi-Channel Remote Transmitter | Page 15 |
| General Care and Maintenance of your Awning | Page 16 |
| Care and Maintenance - SunSetter Woven Acrylic Fabric | Page 17 |
| Care and Maintenance - Electric Motor and Remote | Page 18 |
| Preparing Your Awning for Winter | Page 18 |
| Changing the Battery in your Remote Transmitter | Page 18 |
| <u>OPTIONAL PROCEDURES</u> | |
| Troubleshooting | Page 19 |
| Adjusting The Open and Close Limits of the Motorized Awning, APPENDIX A | Page 22 |
| Changing the Pitch of your Awning, APPENDIX B | Page 23 |
| How to Drain Water From Your Awning, APPENDIX C | Page 25 |
| Resetting Remote Communication and Reprogramming the Motor, APPENDIX D | Page 26 |
| Add/Delete a Control Device (Remote, Remote Wall Switch, Wind Sensor) | Page 26 |
| Front Roll Down Weatherbreaker, APPENDIX E | Page 27 |
| Awning Removal Procedure, APPENDIX F | Page 28 |
| How to Safely Remove the Bungee Cords from the Cover, APPENDIX G | Page 29 |
| A Place for Your Notes | Page 30 |
| Warranty Information | Page 31 |
| Important Customer Service Information | Back Cover |
| Installer Checklist | Back Cover |

Awning Installation Instructions

WARNING: FAILURE TO FOLLOW THESE INSTRUCTIONS COULD RESULT IN PERSONAL INJURY!

WARNING: DO NOT REMOVE THE PLASTIC SAFETY SLEEVES FROM THE LATERAL ARMS UNTIL INSTRUCTED TO DO SO.

WARNING: NEVER ATTEMPT TO REPAIR OR DISASSEMBLE ANY PART OF THE AWNING WITHOUT FOLLOWING REPLACEMENT PART PROCEDURES SUPPLIED BY THE MANUFACTURER. TRYING TO DO SO WITHOUT PROPER INSTRUCTIONS COULD RESULT IN PERSONAL INJURY!

Before Starting

Before beginning, please familiarize yourself with the components of the Awning as shown in **Figure 1**, and the supplied fasteners/parts shown on **Pages 4 & 5**. Find the Mounting Brackets (wall or soffit) in the package (they are separated from the Awning itself).

Helpers Needed

Use the Awning Weight Chart on **Page 10** to determine how much help is needed to safely lift the Awning into the wall or soffit Brackets.

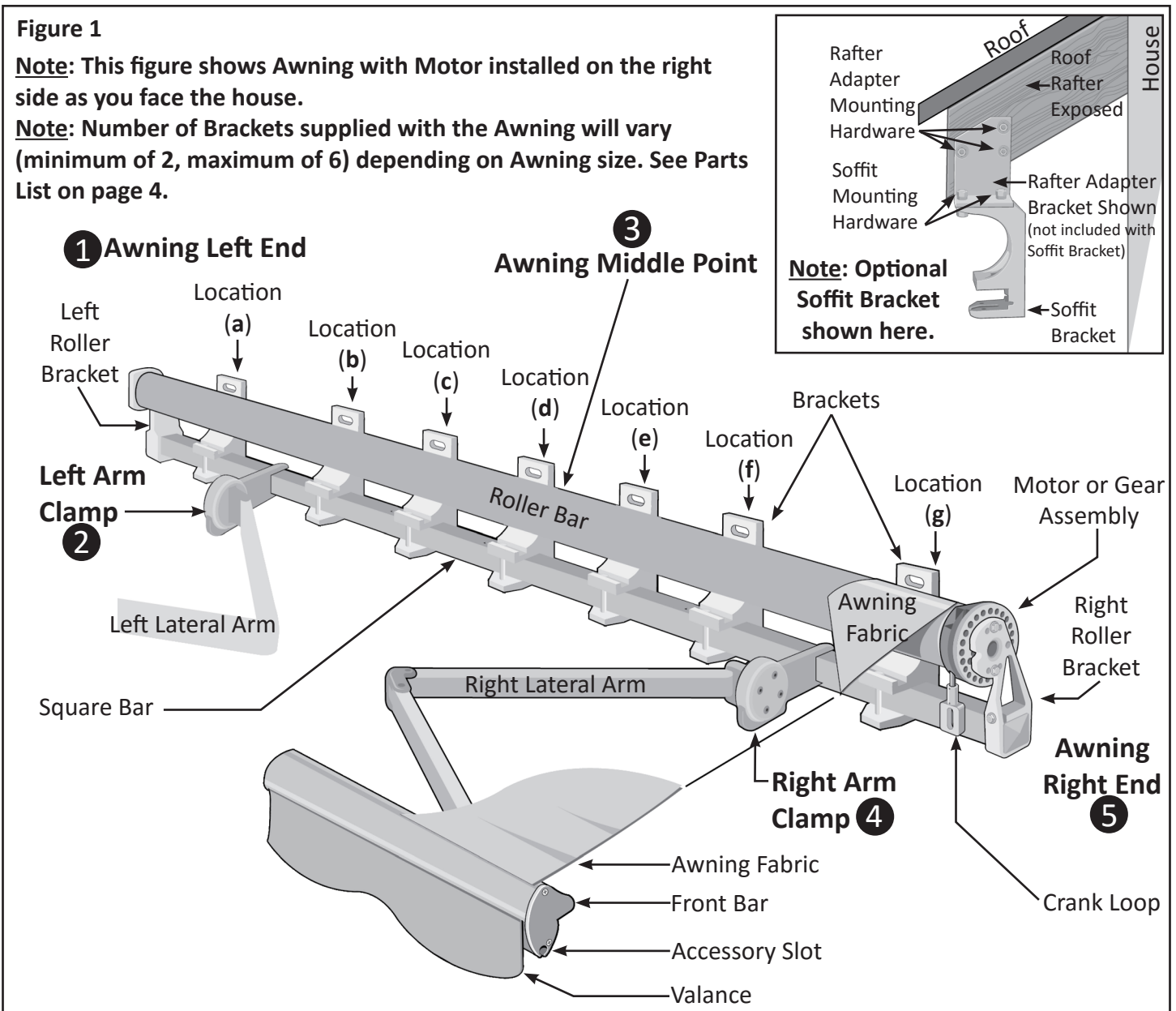

Figure 1a
Bracket Locations for 8' Wide Awnings

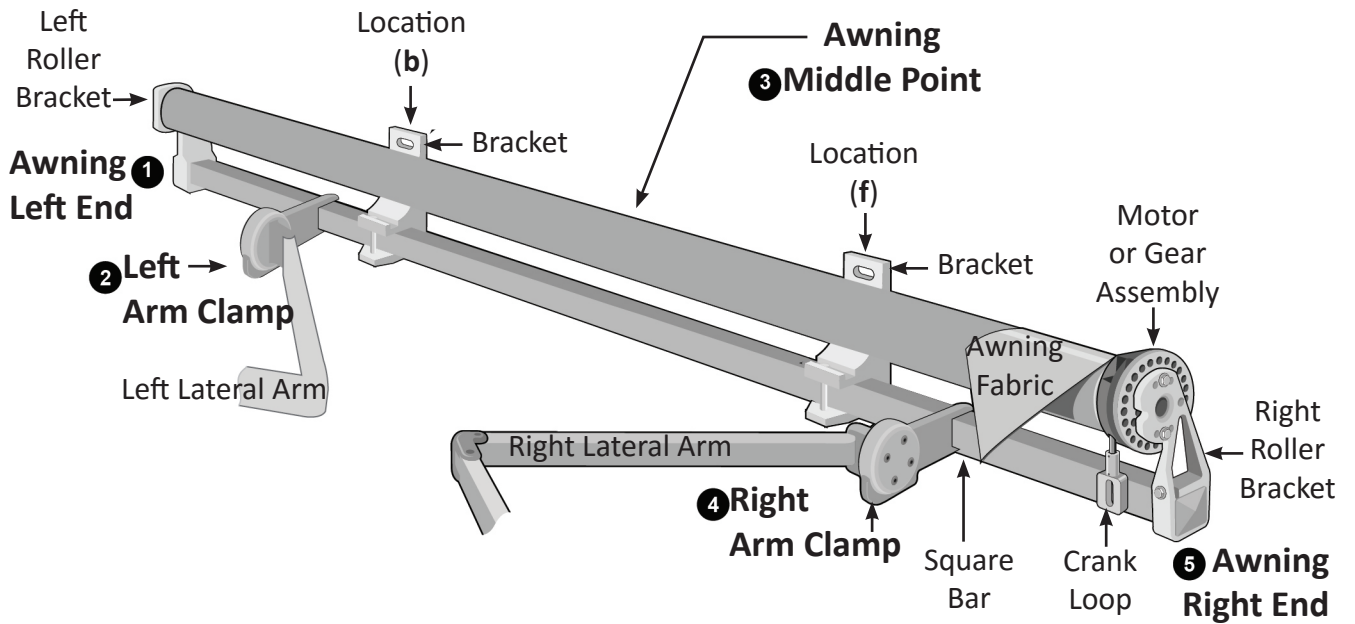

Figure 1b
Bracket Locations for 10' - 13' Wide Awnings

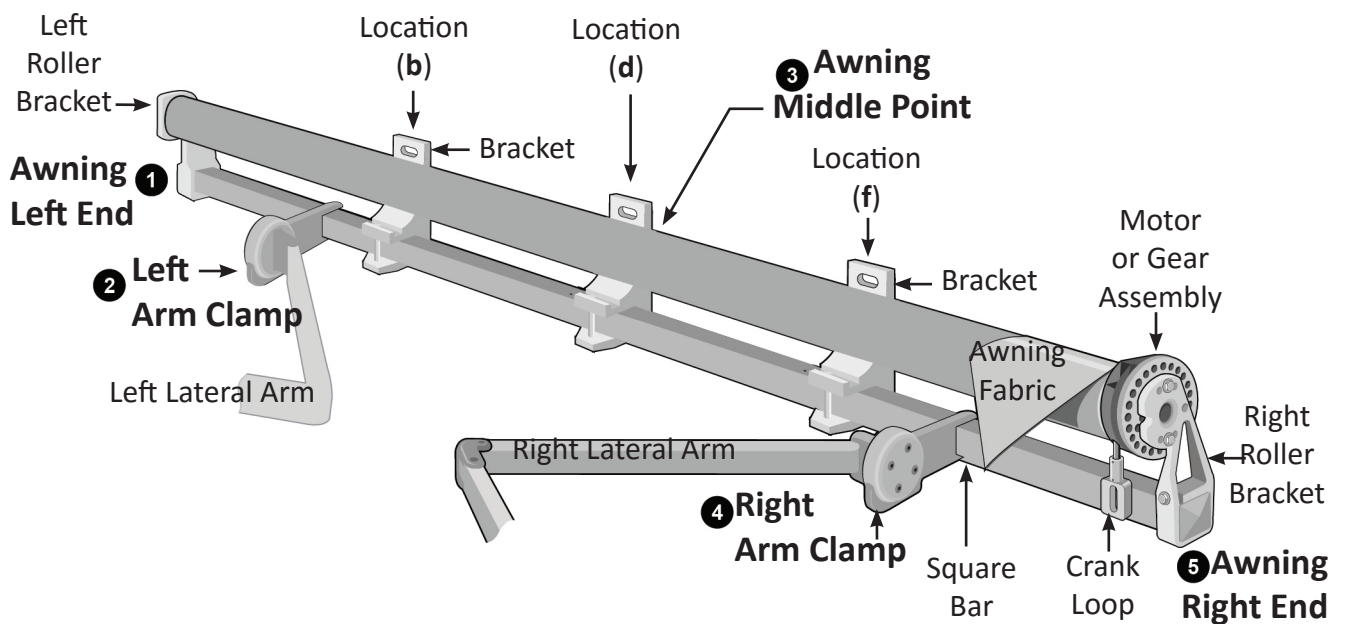

Figure 1c
Bracket Locations for 14' - 16' Wide Awnings

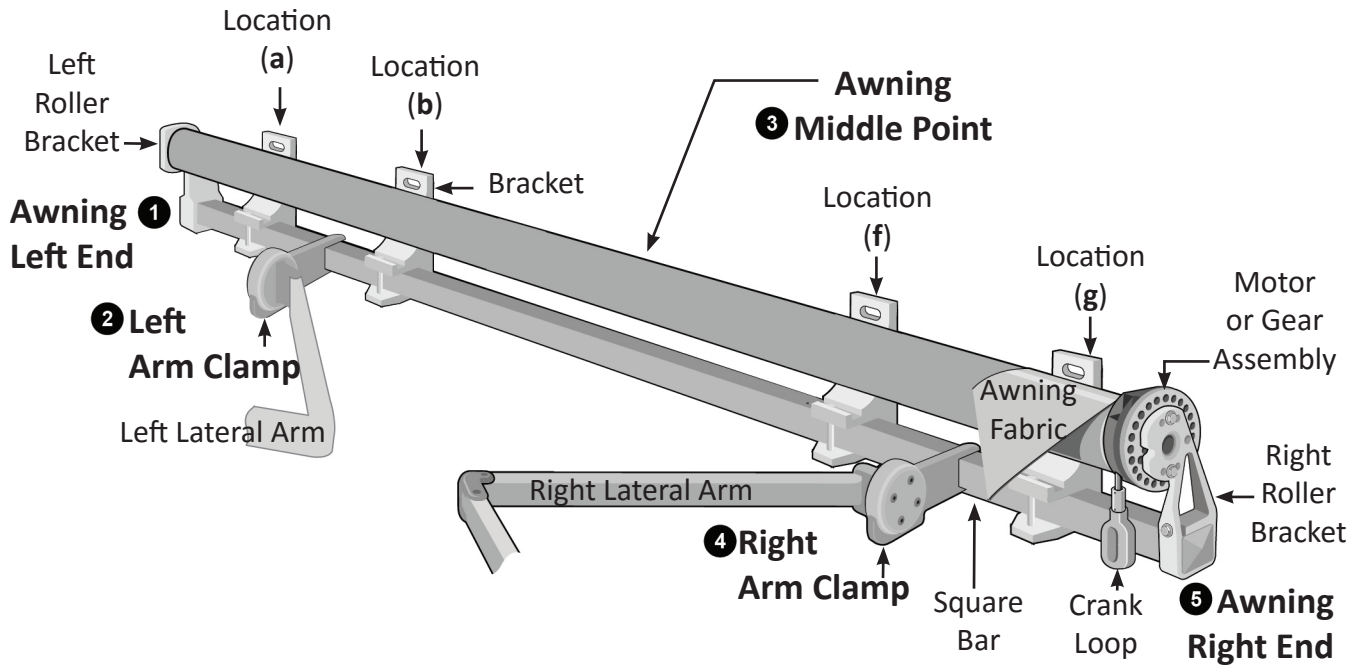
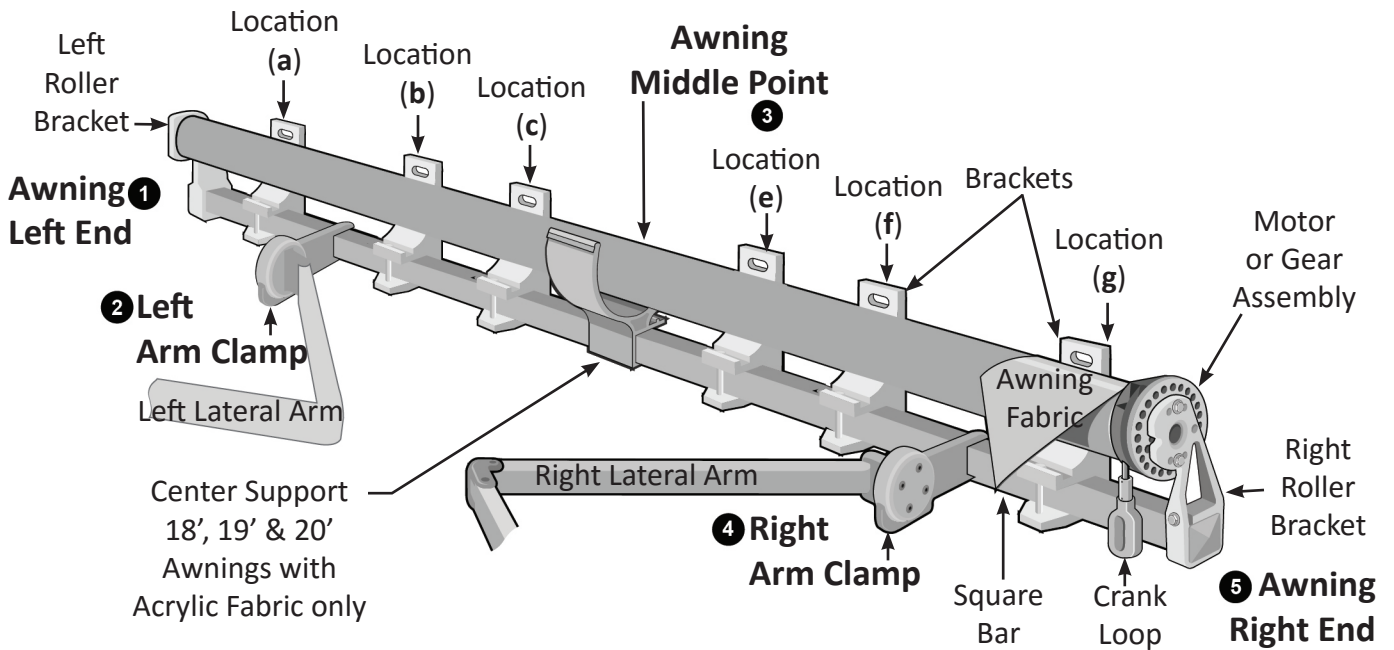

Figure 1d
Bracket Locations for 17' - 20' Wide Awnings



Supplied Fasteners / Parts List

Note: All Awnings ship with one of the following types of Brackets and Mounting Hardware:

Wall Bracket
 8' : Qty 2
 10' - 13' : Qty 3
 14' - 16' : Qty 4
 17' - 20' : Qty 6

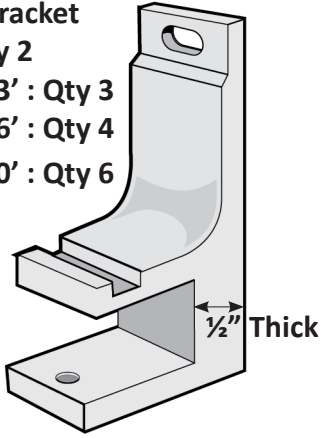

Mounting Hardware Includes:

- Two 4" Lag Screws and Flat Washers for each Wall Bracket
- One Retaining Bolt Set for each Wall Bracket

XL Wall Bracket
 14' - 16' : Qty 4
 17' - 20' : Qty 6

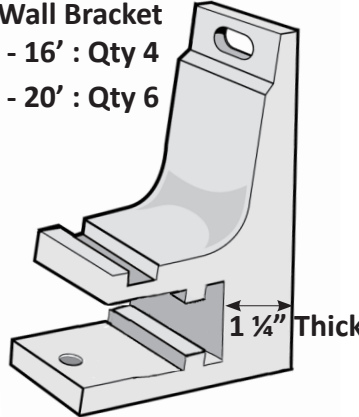

Mounting Hardware Includes:

- One 4" Lag Screw and Flat Washer for each Wall Bracket (use 4" Lag Screw in top Bracket hole)
- One 5" Lag Screw and Flat Washer for each Wall Bracket (use 5" Lag Screw in bottom Bracket hole)
- One Retaining Bolt Set for each Wall Bracket

Soffit Bracket
 8' : Qty 2
 10' - 13' : Qty 3
 14' - 16' : Qty 4
 17' - 20' : Qty 6

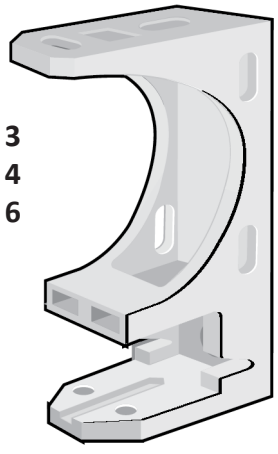

Mounting Hardware Includes:

- Two 4" Lag Screws and Flat Washers for each Soffit Bracket
- Two Retaining Bolt Sets for each Soffit Bracket

Lag Screws and Flat Washers

3/8" Flat Washer
 8' : Qty 4
 10'-13' : Qty 6
 14'-16' : Qty 8
 17'-20' : Qty 12

3/8" x 4" Lag Screw (for all Brackets)
 (Note: For XL Wall Bracket, half the number of 4" Lag Screws are replaced with 5" Lag Screws, as shown below.)
 8' : Qty 4, 10'-13' : Qty 6, 14'-16' : Qty 8, 17'-20' : Qty 12

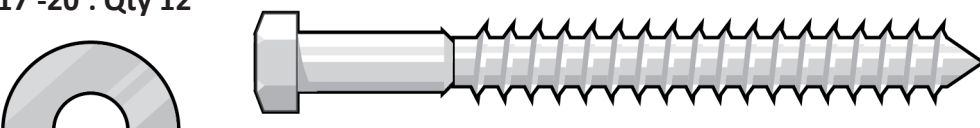

3/8" x 5" Lag Screw (for XL Wall Bracket only)
 14'-16' : Qty 4, 17'-20' : Qty 6
 Use 5" Lag Screw in bottom XL Bracket hole



Retaining Bolt Set
 8' : Qty 2
 10'-13' : Qty 3
 14' - 16' : Qty 4
 17'-20' : Qty 6

5/16" x 2-3/4" Retaining Hex Bolt

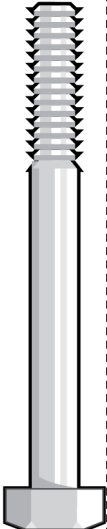

5/16" Retaining Nut



5/16" Flat Washer

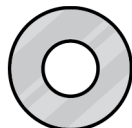

Note: For Soffit Brackets, Double the Number of Bolts, Washers and Nuts.

6 mm Allen Wrench Qty 1

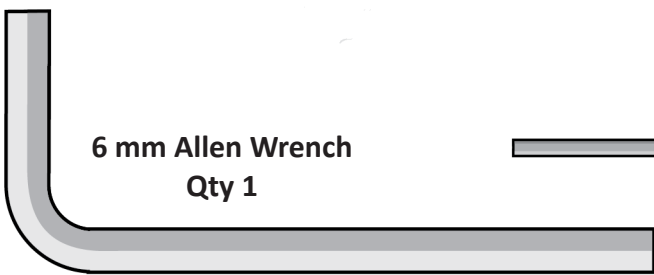

Crank Wand Qty 1

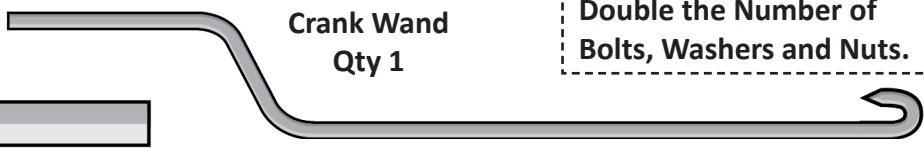

Additional Parts List - Motorized Models Only

MultiChannel Remote Transmitter, Qty 1

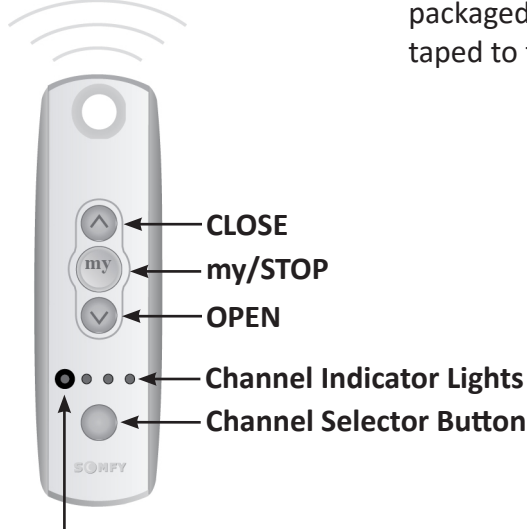

A Spare CR2430 Lithium Battery for the Remote Transmitter is packaged in the clear bubble pack taped to the Motor Power Cord.

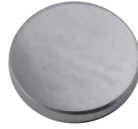

Wall Mount for Remote Transmitter, Qty 1

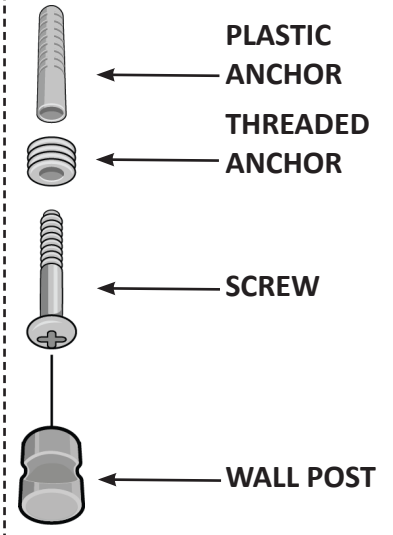

Note: Awning is preset to operate on Channel 1.

- Check the active Channel by briefly pressing the Channel Selector Button. The active Channel Light will blink.
- Change Channel by pressing the Channel Selector Button.
- Press the Channel Selector Button again while the Channel Indicator Light blinks and the next Channel will be selected.

Optional Parts List - Masonry, Brick or Concrete Installations

(available for all models)

$\frac{3}{8}$ " x 6" Masonry Drill Bit, Qty 1 (For Masonry Walls)



- 8' Awning = Qty 4
- 10' - 13' Awning = Qty 6
- 14' - 16' Awning = Qty 8
- 17' - 20' Awning = Qty 12

Note:

For XL Awnings, substitute half of the 4" Masonry Bolts with 5" Masonry Bolts



Other Optional Items Packaged in the Same Tube with your Awning (if purchased with your Awning)

- a. Cover b. Wireless Wind Sensor c. Wireless Wall Switch d. All-Weather Remote

Tools Required

In your package you will find the following tools: 6 mm Allen Wrench.

For any type of WALL or SOFFIT installation you will need an assistant(s), measuring tape, two step-ladders, $\frac{5}{16}$ " socket, chalk line (or string), Phillips screwdriver, pencil, level, electric drill, a $\frac{1}{2}$ " or 13 mm wrench, and a stud finder.

If you have a wood frame construction with wood, vinyl, stucco, or aluminum siding, you will need in addition to the above; $\frac{1}{8}$ " and $\frac{1}{4}$ " drill bits.

If you have masonry construction or brick walls, you also need a $\frac{1}{4}$ " masonry drill bit for drilling holes for Masonry Bolts.

Installation Area

1. Inspect the wall/soffit you plan to mount your Awning on, and be sure you have a clear area with no light fixtures, doors, windows, or downspouts to obstruct your installation. **Check the wall/soffit surface for bows or swells.** If you have these conditions, shimming the Brackets will be required. See **Figure 4, Page 9.**

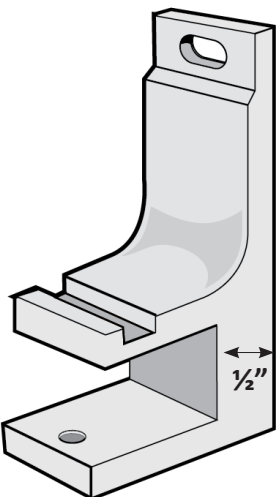
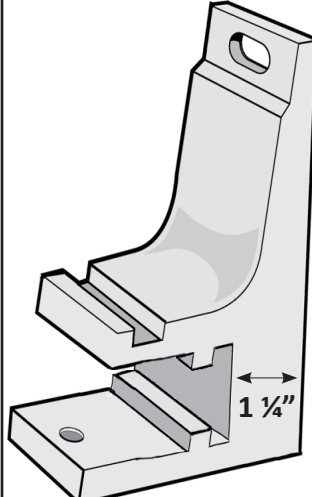
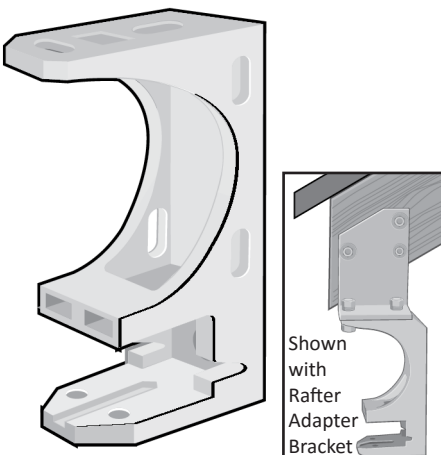
| For Wall Mount Continue Below | | For Soffit Mount Proceed to Page 11 |
|--|---|--|
| <p><u>Standard Wall Brackets</u></p> <p>Use 4" Lag Screw in Top and Bottom Holes of Bracket</p>  <p>$\frac{1}{2}$"</p> | <p><u>XL Wall Brackets</u></p> <p>Use 4" Lag Screw in Top Hole Use 5" Lag Screw in Bottom Hole</p>  <p>$1 \frac{1}{4}$"</p> | <p><u>Soffit Brackets</u></p> <p>Use 4" Lag Screw in both Top Holes</p>  <p>Shown with Rafter Adapter Bracket</p> |

For Soffit Mount Only, skip the "Mounting Height" section below and proceed directly to "Soffit Mount Installation - Mounting Line" on Page 11.

For Wall Mount Only, continue below:

Mounting Height for Wall Brackets

The mounting height (9 ft is optimal) is defined as one inch above the highest part of the Wall Bracket from the deck/patio floor. See **Figure 2 on Page 7.**

Your Awning's pitch (angle) is pre-set at the factory with a drop of 29 inches from the top of the Wall Brackets to the lowest point at the Front Bar of the Awning. For Example, if you mount the Awning on the wall at 9' from the deck or patio, the lowest point at the Front Bar of the Awning at full projection will be 6' 6". See **Figure 3 on Page 7.** The Awning pitch (angle) can be adjusted after installing the Awning.

To assure head clearance at the front of the Awning, we recommend to install the Awning above 7' 6" from the deck or patio, with an optimal mounting height of 9' or above.

Note: When making the decision on the Mounting Height, the Awning requires :

- 8" of unobstructed area along the whole length of the Awning to fit **all Brackets** on your wall **without a Hood**.
- 9" of unobstructed area along the whole length of the Awning for **Standard Wall Brackets with a Hood**.
- 11" of unobstructed area along the whole length of the Awning for **XL Wall Brackets with a Hood**.

See **Figure 2** under "Standard Wall Mount" or "XL Wall Mount," whichever is appropriate for your installation.

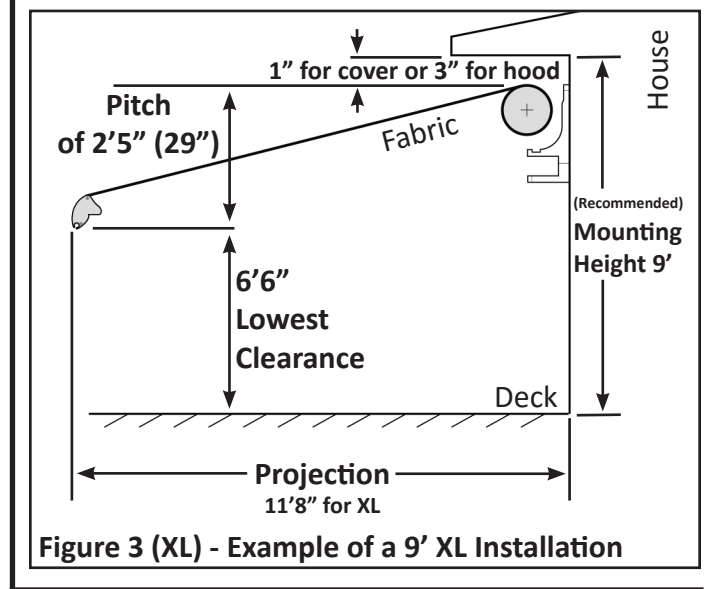
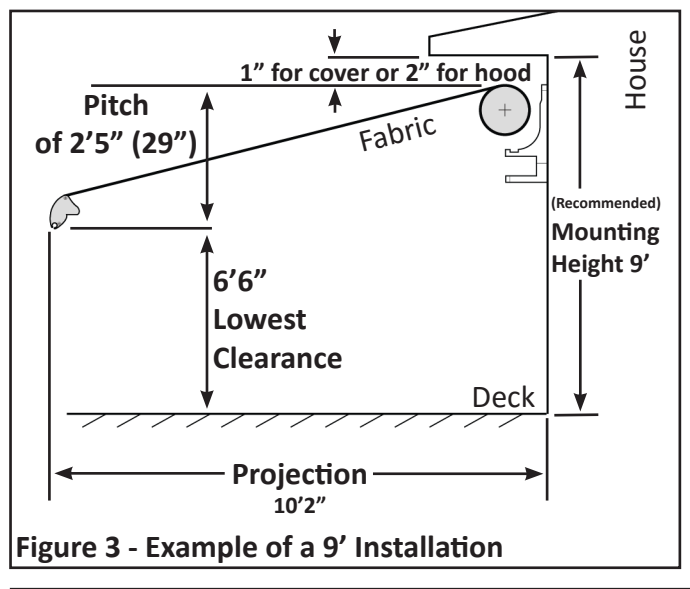
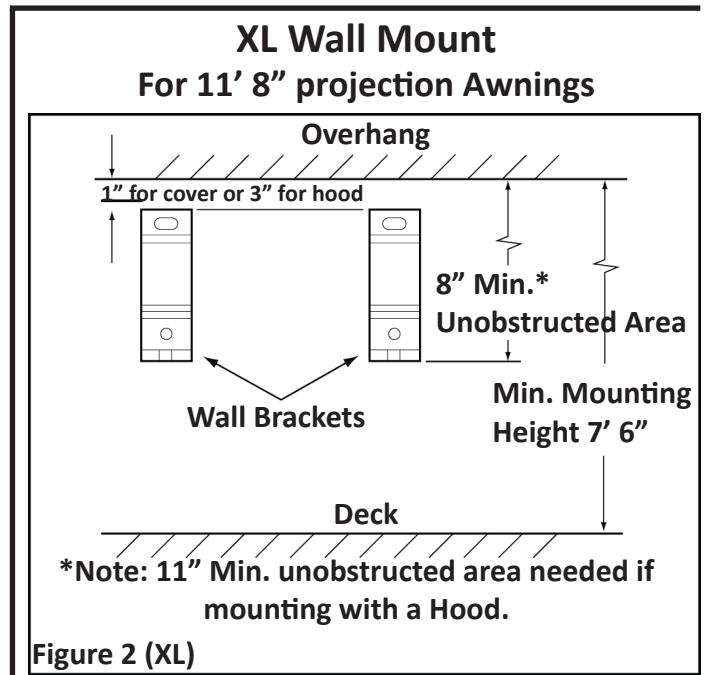
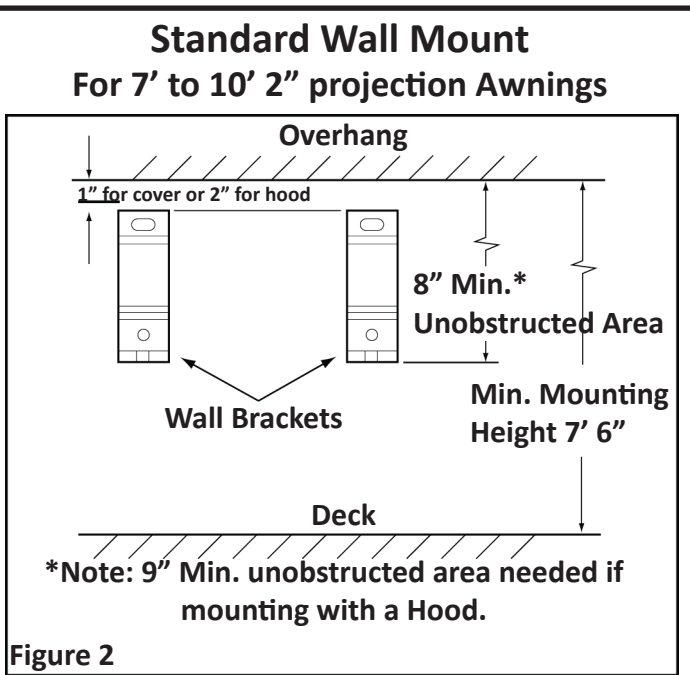

2. Mark the Mounting Line on the Wall

- Measure up from the deck or patio floor on one side and make a mark at your desired Mounting Height (should be at least 7' 6").
- Make a second mark 8" below the first mark. The space between these marks must be clear of obstructions (light fixtures, etc.) along the entire length of the wall.
- Using a chalk line or a string, snap a level line on the lower mark for the length of the Awning. The bottom of the Wall Brackets will rest on this lower line.

Note: For ease of mounting the Awning into the Brackets, it is very important that the line will be straight and level.

Wall Bracket Locations

CAUTION: PROPER LOCATION OF THE BRACKETS IS THE MOST IMPORTANT ASPECT OF THE AWNING MOUNTING. IT IS CRITICAL THAT YOU FASTEN BOTH LAG SCREWS IN EACH MOUNTING BRACKET TO STUDS, JOISTS, HEADERS OR OTHER MAJOR STRUCTURAL MEMBERS.

Even a moderate wind exerts great force on the Awning and Mounting Brackets. This is why it is important that both Lag Screws in each Mounting Bracket be fastened properly and securely. Proper location will also make it easier to insert the pre-assembled Awning into the supporting Brackets.

WARNING: FAILURE TO PROPERLY AND SECURELY FASTEN BOTH LAG SCREWS IN EACH WALL BRACKET TO THE WALL COULD RESULT IN THE COLLAPSE OF THE AWNING AND CAUSE PERSONAL INJURY.

Note: Mount all supplied Brackets only in the locations recommended for your Awning size. See Figures 1a-1d on Pages 2 and 3 for your size Awning.

Note: You will need to install ALL Brackets supplied with your Awning for secure mounting.

Description of Wall Bracket Locations

For 8' wide Awning, install **two** Brackets supplied at the locations (b) and (f). See Fig. 1a.

For 10' to 13' wide Awnings, install **three** Brackets supplied at the locations (b), (d) and (f). See Fig. 1b.

For 14', 15', and 16' wide Awnings, install **four** Brackets supplied at the locations (a), (b), (f) and (g). See Fig. 1c.

For 17' to 20' wide Awnings, install **six** Brackets supplied at the locations (a), (b), (c), (e), (f) and (g). See Fig. 1d.

Location (a) - Between the left end of the Awning and the left Arm, on the stud nearest to the left end.

Location (b) - Between the two Arms, on the nearest stud to the left Arm.

Location (c) - On the nearest stud about 2' from the middle point of the Awning, toward the left.

Location (d) - On the nearest stud to the middle point of the Awning. (Size 10' - 13' only)

Location (e) - On the nearest stud about 2' from the middle point of the Awning, toward the right.

Location (f) - Between the two Arms, on the nearest stud to the right Arm.

Location (g) - Between the right end of the Awning and the right Arm, on the stud nearest to the right end.

3. On the chalk line you have marked on the house, mark the left and right ends of the Awning (points 1 and 5 in Figure 1).

Note: With the exception of the 10' Awning, which measures 123" left to right, all other Awnings measure like their defined size. For example, a 12' Awning measures 144" from left to right.

- Using your Awning, measure the distance from the right end of the Square Bar to the inner and outer edges of the right Arm Clamp and record those measurements.
- Repeat this measurement for the left Arm Clamp.
- Mark on the chalk line the middle point and the points where the left and right Arm Clamps will be located (points 2, 3 and 4 in Figure 1 respectively).

Note: The Brackets cannot be installed in the area where the Arm Clamps are located.

Installing the Brackets on Wood Frame Walls w/Wood, Vinyl, Stucco or Aluminum Siding

For Installing the Brackets on masonry, brick, or concrete walls, proceed to "Installing the Brackets on Masonry, Brick, or Concrete Wall" after Step 8 on Page 9.

For wall mount on wood frame walls, continue with Step 4.

4. LOCATE THE STUDS, JOISTS OR HEADERS IN THE AREA IN WHICH EACH BRACKET MUST BE INSTALLED AS EXPLAINED EARLIER IN "Wall Bracket Locations".

If your Awning is going on a wall that has a window or a door, use these steps to locate the studs inside your home and transfer those measurements to the outside. Get a roll of duct tape or similar tape. From inside your home on the wall that your Awning will be installed on, place a piece (about 6" strip) of duct tape vertically on the window pane.

Using a stud finder locate a stud on the same inside wall, and mark the center of the stud. Measure from the tape or door to the center of the stud, and write the measurement down. Continue to locate the additional studs and record those measurements.

On the outside wall, using the inside measurements, measure from the tape or door to the location of the center of the studs. Mark the centers of each stud, on which a Bracket will be installed, with a 7" vertical line.

Note: Spacers or Shims can be used under Brackets for an attractive and finished appearance on uneven siding. For Vinyl or Aluminum Siding, shimming beneath the siding in each Bracket location may provide a more solid surface for mounting.

See Figure 4.

Note: Shims (optional) are not supplied with your SunSetter Awning.

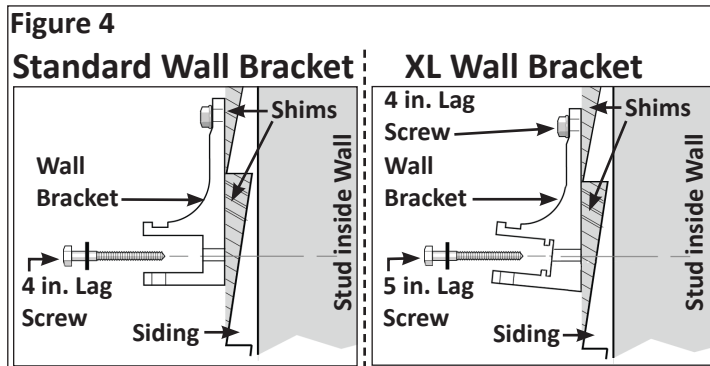

5. Position the Bracket on the wall (or on the shim), centered over the vertical line, with the bottom of the Bracket even with the lower horizontal chalk line. Using a level, plumb (center) the Bracket vertically, then mark the top and bottom holes. See Figure 5.

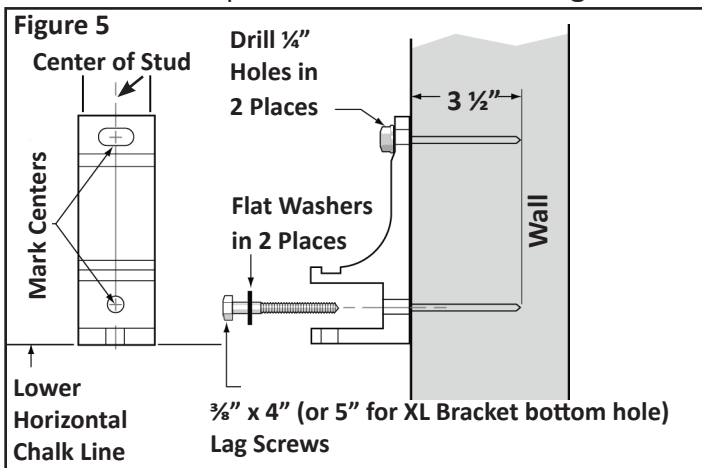

6. Remove the Bracket and drill the top hole through the siding block or shim (if appropriate) and about 3 1/2" into the stud or joist using a 1/4" drill bit. This will prevent the framing from splitting while installing the Lag Screws.

Using a level, ensure the bottom hole is plumb under the top hole, then drill the bottom hole.

WARNING: YOU MUST SECURELY FASTEN BOTH LAG SCREWS IN EACH MOUNTING BRACKET TO THE STUDS. SOME HOMES MAY REQUIRE LONGER LAG SCREWS. PLEASE CONSULT WITH A LOCAL HANDYMAN OR CONTRACTOR IF APPROPRIATE. FAILURE TO DO SO COULD RESULT IN COLLAPSE OF THE AWNING AND CAUSE PERSONAL INJURY.

7. Using a 3/16" socket, install the Bracket with the two 3/8" x 4" (or 5" bottom screw for XL) long Lag Screws. Use the flat washer provided under the head of the screw. While tightening the Lag Screws, keep the Bracket plumb (use level if needed). Do not overtighten the lag screws; doing so may split the wood framing or weaken the screws. See Figure 5.

8. Repeat for all Brackets.

Proceed to Step 15 on Page 10, under "Securing the Awning into the Brackets."

Installing the Brackets on Masonry, Brick, or Concrete Walls.

WARNING: SOME BRICK WALLS MIGHT NOT BE STRONG ENOUGH TO SAFELY SUPPORT AN AWNING. THE SUPPLIED FASTENERS ARE NOT DESIGNED TO ATTACH THE AWNING TO VENEER BRICK WALLS OR TO "SOFT BRICKS." WE SUGGEST CONSULTING A LOCAL HANDYMAN OR CONTRACTOR FOR PROPER MOUNTING.

WARNING: FAILURE TO SECURELY FASTEN BOTH MASONRY BOLTS IN EACH MOUNTING BRACKET TO THE WALL OR, FAILURE OF THE WALL TO SUPPORT AN AWNING COULD RESULT IN THE COLLAPSE OF THE AWNING AND CAUSE PERSONAL INJURY.

9. Using the chart below, mark on the wall the location of the Brackets and draw a 7 in. vertical line at each location.

| Recommended Locations for Masonry Type Walls | | | | | | | |
|--|-------------|------------------------|--------------|--------------|--------------|-------------------------|-------------|
| Size | Loc.(a) | Loc.(b) | Loc.(c) | Loc.(d) | Loc.(e) | Loc.(f) | Loc.(g) |
| 8' | N/A | 8" from end | N/A | N/A | N/A | 8" from end | N/A |
| 10' | N/A | 5" from end | N/A | 61" | N/A | 5" from end | N/A |
| 11' | N/A | 10" from end | N/A | 66" | N/A | 10" from end | N/A |
| 12' | N/A | 14" from end | N/A | 72" | N/A | 14" from end | N/A |
| 13' | N/A | 20" from end | N/A | 78" | N/A | 20" from end | N/A |
| 14' | 5" from end | 26" from end | N/A | N/A | N/A | 26" from end | 5" from end |
| 15' | 5" from end | N/A | N/A | N/A | N/A | N/A | 5" from end |
| 16' | 5" from end | 4" from left arm clamp | N/A | N/A | N/A | 4" from right arm clamp | 5" from end |
| 17' | 5" from end | | 70" from end | N/A | 70" from end | | 5" from end |
| 18' | 5" from end | | 76" from end | N/A | 76" from end | | 5" from end |
| 19' | 5" from end | | 82" from end | N/A | 82" from end | | 5" from end |
| 20' | 5" from end | 88" from end | N/A | 88" from end | N/A | 88" from end | 5" from end |

10. Position the Bracket on the wall, centered over the vertical line, with the bottom of the Bracket even with the lower horizontal chalk line. Using a level, plumb the Bracket vertically, then mark the two holes. See Figure 6.

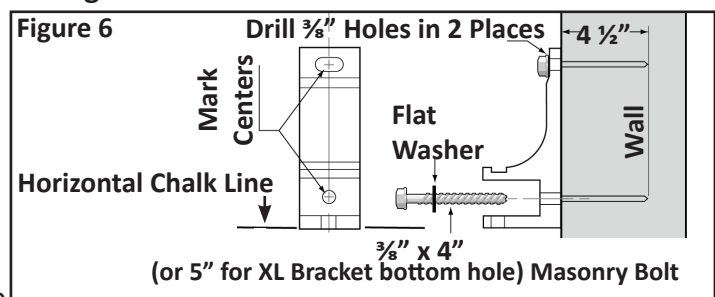

CAUTION: The masonry fasteners that are supplied with this Awning **ARE NOT** designed for use in the joint between two bricks. They are **ONLY** to be installed within the main body of a brick, not within $\frac{1}{2}$ " of an outer edge of the brick (See Figure 7). The fasteners are also not suitable for hollow cinder block type construction or wall surfaces that have deteriorated. Consult a local hardware store for fasteners that fit these types of applications. Do not use the supplied masonry fasteners on a stucco wall.

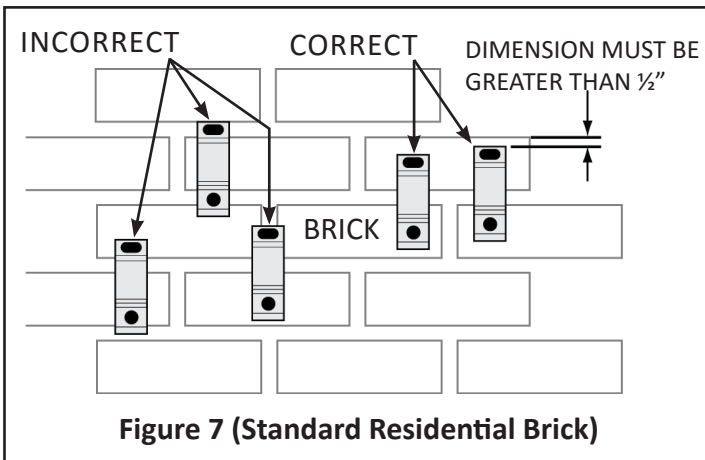

11. Remove the Bracket and drill a $\frac{1}{4}$ " pilot hole using a masonry drill bit, about 3" deep for the top hole. Make sure the bottom hole is plumb (vertically centered) under the top hole, then drill the bottom hole.

12. Using the $\frac{3}{8}$ " masonry bit supplied, drill both holes $4\frac{1}{2}$ " deep.

Note: Do not allow the holes to become tapered or oversized while drilling to this final size.

CAUTION: You must drill these holes in the two specified steps. If you do not follow these steps, the size of the hole can become too large and the masonry bolts will not hold properly.

13. Place a flat washer under the head of the masonry bolt and screw it into the hole using a $\frac{9}{16}$ " socket. See Figure 6. Repeat for other bolt. While tightening the bolts, make sure to keep the Bracket plumb (use a level if needed). Do not overtighten the bolts.

WARNING: YOU MUST BE SURE THE MASONRY BOLTS ARE TIGHT IN THE HOLES. IF NOT, REMOVE THEM AND CONSULT A LOCAL HARDWARE STORE FOR FASTENERS THAT FIT YOUR APPLICATION.

14. Repeat for all Brackets.

Securing the Awning into the Brackets

15. If a Protective Cover or Aluminum Hood was included with your order, please install it now. Follow the instructions included with the Protective Cover or Aluminum Hood and then resume with **Step 16**. If you do not have a Cover or Hood, please consider protecting your Awning now by calling Sunsetter Customer Service at **800-670-7071** to order one.

16. Carefully remove all packaging material from the Awning. **DO NOT REMOVE THE PLASTIC SAFETY SLEEVES FROM THE ARMS.** See Figure 16 on page 13.

17. Separate the Hand Crank Wand from the Awning.

18. Insert the retaining nut into the special groove in each Bracket. See Figure 8.

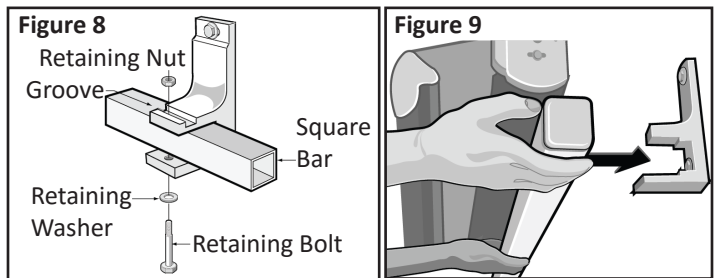

Use the following weight chart to decide how much help you need to safely lift the Awning overhead.

| Awning Weight Chart | | | | | |
|---------------------|---------|-----------|--------------|---------|---------|
| Size | Vista | Motorized | Motorized XL | PRO | PRO XL |
| 8' | 65 lbs | 70 lbs | n/a | 81 lbs | n/a |
| 10' | 80 lbs | 85 lbs | n/a | 98 lbs | n/a |
| 11' | 85 lbs | 90 lbs | n/a | 105 lbs | n/a |
| 12' | 90 lbs | 95 lbs | n/a | 111 lbs | n/a |
| 13' | 95 lbs | 100 lbs | n/a | 117 lbs | n/a |
| 14' | 100 lbs | 110 lbs | 118 lbs | 129 lbs | 137 lbs |
| 15' | 105 lbs | 115 lbs | 123 lbs | 135 lbs | 155 lbs |
| 16' | 110 lbs | 120 lbs | 128 lbs | 141 lbs | 162 lbs |
| 17' | 115 lbs | 125 lbs | 133 lbs | 148 lbs | 171 lbs |
| 18' | 120 lbs | 130 lbs | 138 lbs | 154 lbs | 178 lbs |
| 19' | n/a | 135 lbs | 142 lbs | 160 lbs | 185 lbs |
| 20' | n/a | 140 lbs | 148 lbs | 167 lbs | 194 lbs |

19. With the proper help, lift the Awning (**with the Fabric/Roller Bar positioned above the Square Bar**) into the Brackets and position it so the ends of the Awning line up with end points marked on the wall. See Figure 9.

Push the Square Bar into the Brackets (see Figure 9) and secure with a Retaining Bolt in each Bracket (see Figure 8). Be sure to insert the Retaining Bolt from the bottom of the Bracket, up. You might need to apply pressure on the Square Bar to permit insertion.

Go To "Check Your Awning for Proper Operation" on Page 13.

Soffit Mount Installation - Mounting Line

WARNING: DO NOT REMOVE THE PLASTIC SAFETY SLEEVES FROM THE LATERAL ARMS UNTIL INSTRUCTED TO DO SO. See Figure 16 on Page 13.

Note: The following instructions are for installing to a level overhang or soffit. If installing to an angled overhang or rafters, it may be necessary to use **Rafter Adapter Brackets** (see Figure 10 insert). These Brackets may be purchased separately and utilized as shown in Figure 10. Please call Customer Service at 800-670-7071 to purchase the Rafter Adapter Brackets.

20. Snap a horizontal straight line on the soffit, using the chalk line, the length of the Awning. When you position your chalk line on the soffit, take into account that when retracted, the Awning will project 10" from the chalk line. See Figure 10.

Note: For ease of mounting the Awning to the Brackets, it is very important that the line be straight.

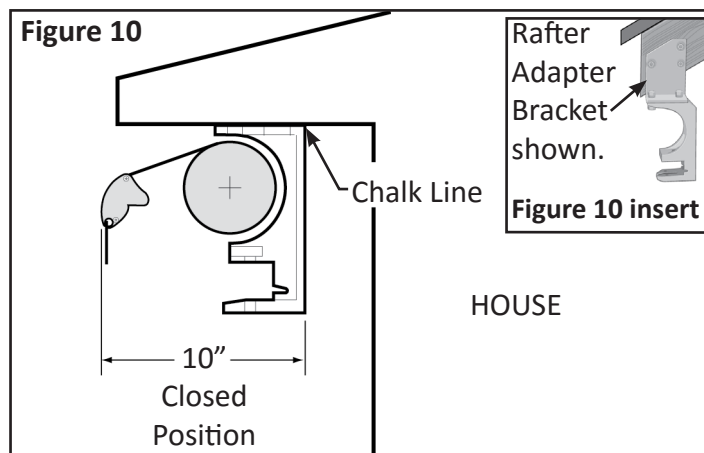

Soffit Bracket Locations

CAUTION: PROPER LOCATION OF THE BRACKETS IS THE MOST IMPORTANT ASPECT OF THE AWNING MOUNTING. IT IS CRITICAL THAT YOU FASTEN BOTH LAG SCREWS IN EACH MOUNTING BRACKET TO THE RAFTERS OR OTHER MAJOR STRUCTURAL MEMBERS.

Even a moderate wind exerts great force on the Awning and Mounting Brackets. This is why it is most important that both Lag Screws in the Brackets be fastened properly and securely. Proper location will also make it easier to insert the pre-assembled Awning into the supporting Brackets.

Note: Mount Brackets only in the locations recommended for your size Awning.

Note: You will need to install ALL Brackets supplied for secure mounting.

Description of Soffit Bracket Locations

For 8' wide awnings, install **two Brackets** supplied at the Locations (b) and (f). See Figure 1a on Page 2.

For 10' to 13' wide Awnings, install the **three Brackets** supplied at the Locations (b), (d), and (f). See Figure 1b on Page 2.

For 14', to 16' wide Awnings, install **four Brackets** supplied at the Locations (a), (b), (f), and (g). See Figure 1c on Page 3.

For 17' to 20' wide Awnings, install **six Brackets** supplied at Locations (a), (b), (c), (e), (f), and (g). See Figure 1d on Page 3.

Location (a) - Between the left end of the Awning and the left Arm, on the Rafter nearest to the left End.

Location (b) - Between the two Arms, on the nearest Rafter to the left Arm.

Location (c) - On the nearest Rafter about two feet from the Middle Point of the Awning.

Location (d) - On the nearest Rafter to the Middle Point of the Awning. (Size 10' to 13' only)

Location (e) - On the nearest Rafter about two feet from the Middle Point of the Awning.

Location (f) - Between the two Arms, on the nearest Rafter to the right Arm.

Location (g) - Between the right End of the Awning and the right Arm, on the Rafter nearest to the right End.

Mounting the Brackets into the Soffit

21. On the Chalk Line you have marked on the soffit, mark the left and the right Ends of the Awning (points 1 & 5 in Figure 1).

Note: With the exception of the 10' Awning, which measures 123" left to right, all other Awnings measure like their defined size. For example, a 12' Awning measures 144" from left to right.

- Using your Awning, measure the distance from the right end of the Square Bar to the inner and outer edges of the right Arm Clamp and record those measurements.
- Repeat this measurement for the left Arm Clamp.
- Mark on the chalk line the Middle Point and the Points where the left and right Arm Clamps will be located (points 2, 3, and 4 in Figure 1 respectively).

Note: The Brackets cannot be installed in the area where the Arm Clamps are located.

22. LOCATE THE RAFTERS IN THE AREA IN WHICH EACH BRACKET MUST BE INSTALLED AS EXPLAINED EARLIER IN “Soffit Bracket Locations” on Page 11.

To find the Rafters, use a stud finder. Mark the center of each Rafter, on which a Bracket will be installed with a 7” long line.

23. Position the Bracket against the soffit, centered over the vertical line, with the back of the Bracket even with the horizontal chalk line (see **Figure 10** on **Page 11**), and mark the two holes. See **Figure 11**.

24. Drill $\frac{1}{4}$ ” pilot holes about $3\frac{1}{2}$ ” into the rafter. This will prevent the framing from splitting while installing the Lag Screws.

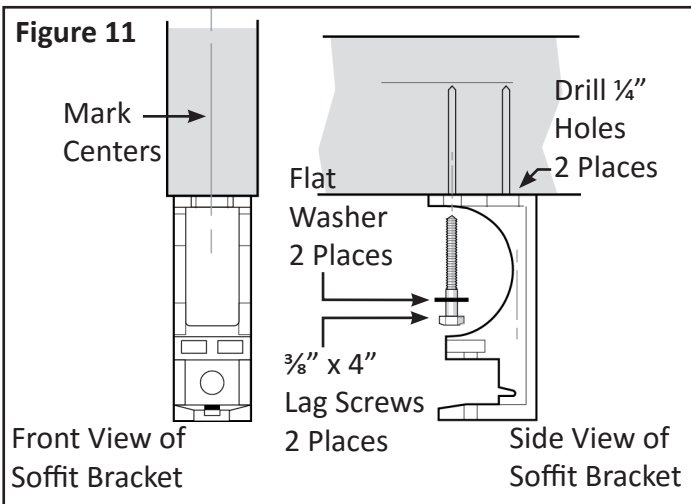

25. Using a $\frac{9}{16}$ ” socket, install the Bracket with the $\frac{3}{8}$ ” x 4” Long Lag Screws. Use the Flat Washer provided under the head of the Screw. Make sure not to overtighten the Lag Screws; doing so may split the wood framing or weaken the Screw. See **Figure 11**.

WARNING: FAILURE TO PROPERLY AND SECURELY FASTEN BOTH LAG SCREWS IN EACH MOUNTING BRACKET TO STRUCTURAL MEMBERS OF THE SOFFIT OR, FAILURE OF THE STRUCTURAL MEMBER TO SUPPORT AN AWNING COULD RESULT IN THE COLLAPSE OF THE AWNING AND CAUSE PERSONAL INJURY.

26. Repeat for all Brackets.

Note: If the Protective Vinyl Cover was purchased together with your Awning proceed to Step 27. If not, proceed to Step 31 under “Securing the Awning into the Soffit Bracket” on Page 13, to continue with the installation of your Awning.

Protective Cover Installation - Soffit

27. Locate the supplied Fasteners and Screws used to secure the Protective Cover to the soffit. See **Figure 13**.

Note: We recommend installing the Fasteners for the Protective Cover one at a time, beginning with the one to the far right. Once the first is installed, you will use the actual Protective Cover as the template for the Grommet spacing between all holes.

28. Make a mark 1” in front of the Soffit Bracket. See **Figure 12**.

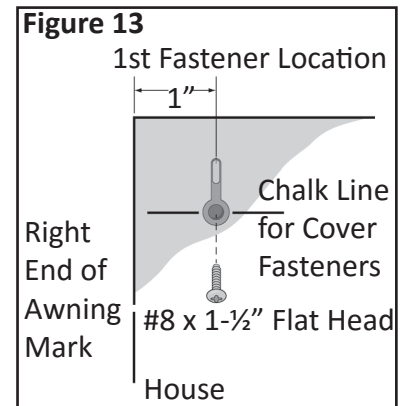
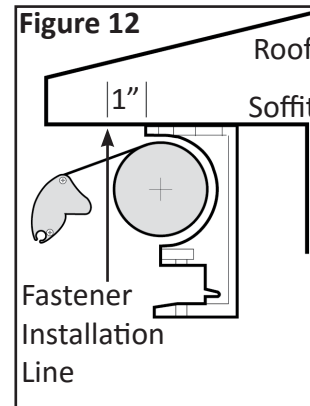

29. On the mark, snap a chalk level line along the entire length of the Awning. On the chalk line, mark the location of the right end of the Awning. Along the chalk line you just made, measure 1” further to the right of the Awning end point and make a mark. This is the location of the first fastener on the right for the Protective Cover. See **Figure 13**.

30. Attach the Cover Fasteners to the Soffit:

- Place one Fastener on the mark. Orient the fastener so that the hook opening is facing in towards the house. See **Figure 14** on **Page 13**.
- Using a $\frac{1}{8}$ ” drill bit, drill a pilot hole approximately 1” deep. Secure the fastener with a #8 x 1- $\frac{1}{2}$ ” Phillips screw, supplied.
- Remove the Cover from its packaging. Orient the Cover so that the sewn hem is facing the house. See **Figure 14**. Place the first grommet of the Protective Cover on the first installed Fastener.
- Extend the Cover to the left and keep it taut. Then mark the center of the next Grommet hole centered on the chalk line.
- Repeat the previous steps for the remaining fasteners.

Note: The ends of the Protective Cover are designed to extend approximately 1- $\frac{1}{2}$ ” beyond the overall width of the Awning.

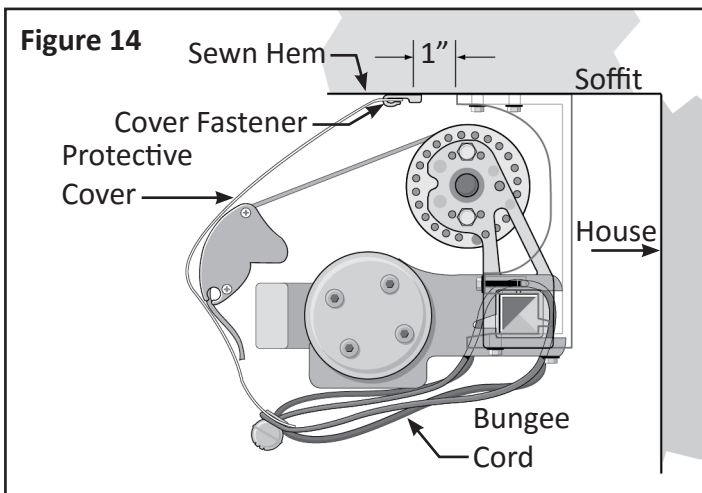

OFF SEASON STORAGE ONLY

Use the supplied Bungee Cords to secure Protective Cover in place. See **Figure 14**. Slide the loop end of the Bungee through the bottom Grommets from the outside of the cover, pull the cord over and around the Square Bar and place over the ball that secures the cord.

Remove bungee cords before using your awning.

Securing the Awning into the Soffit Brackets

31. Carefully remove all packaging from the Awning.

DO NOT REMOVE THE PLASTIC SAFETY SLEEVES FROM THE ARMS. See **Figure 16**.

32. Separate the Wand from the Awning.

33. Insert a Retaining Nut into each of the two special slots in each Bracket. See **Figure 15**.

34. With proper help, lift the Awning (**with Fabric Roller Bar above the Square Bar**) into the Brackets (See **Figure 15 Insert**) and position so the ends line up with end points marked on the wall. Use the following weight chart to decide how much help you need.

| Awning Weight Chart | | | | | |
|---------------------|---------|-----------|------------|---------|---------|
| Size | Vista | Motorized | Motor'd XL | PRO | PRO XL |
| 8' | 65 lbs | 70 lbs | n/a | 81 lbs | n/a |
| 10' | 80 lbs | 85 lbs | n/a | 98 lbs | n/a |
| 11' | 85 lbs | 90 lbs | n/a | 105 lbs | n/a |
| 12' | 90 lbs | 95 lbs | n/a | 111 lbs | n/a |
| 13' | 95 lbs | 100 lbs | n/a | 117 lbs | n/a |
| 14' | 100 lbs | 110 lbs | 118 lbs | 129 lbs | 137 lbs |
| 15' | 105 lbs | 115 lbs | 123 lbs | 135 lbs | 155 lbs |
| 16' | 110 lbs | 120 lbs | 128 lbs | 141 lbs | 162 lbs |
| 17' | 115 lbs | 125 lbs | 133 lbs | 148 lbs | 171 lbs |
| 18' | 120 lbs | 130 lbs | 138 lbs | 154 lbs | 178 lbs |
| 19' | n/a | 135 lbs | 142 lbs | 160 lbs | 185 lbs |
| 20' | n/a | 140 lbs | 148 lbs | 167 lbs | 194 lbs |

35. Push the Square Bar into the Brackets and secure with two Retaining Bolts in each Bracket. Be sure to insert the bolt from the bottom of the Bracket, up. You might need to apply pressure on the Square Bar to permit insertion of the bolts. See **Figure 15**.

Proceed to "Check Your Awning for Proper Operation" to complete the installation of your Awning.

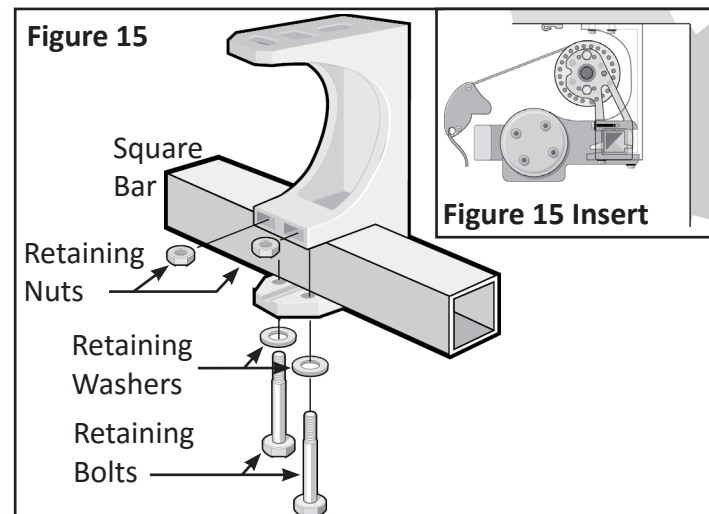

Check Your Awning for Proper Operation

Note: For Motorized Awnings - Do not plug the power cord into the outdoor (GFI) outlet yet.

WARNING: BEFORE REMOVING THE PLASTIC SAFETY SLEEVES, MAKE SURE NO LADDER, PERSON OR OBJECT IS IN FRONT OF THE AWNING. FAILURE TO DO SO COULD RESULT IN PERSONAL INJURY. See **Figure 16**.

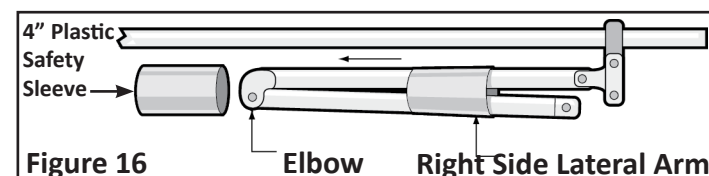

36. Position yourself under the Awning, then remove the plastic safety sleeves from the arms one at a time.

Note: Do not use a knife or blade to cut the safety sleeves. When removed, do not discard, retain for future use.

Note: For 18', 19' and 20' Awnings with Woven Acrylic Fabric only, be sure to note the special instructions attached to the Center Support.

Motorized Awnings continue at Step 37 on Page 14.
VISTA Awnings proceed to Step 40 under "Test for Proper Operation," on Page 14.

37. Plug the electric cord into your outdoor ground fault (GFI) receptacle.

38. We have also supplied a wall mount for the Remote Transmitter. See the “**Additional Parts List**” on **Page 5**. Simply position the Wall Post at the desired location, mark the hole location and secure with the supplied hardware, if needed.

CAUTION: Do not permit the hand-held Remote Transmitter to get wet as this can affect its proper operation. It is recommended to install the Wall Holder inside the house.

Note: During an electrical outage, you can open or close your awning using the supplied Crank Wand. Just insert the Wand into the crank loop and turn. See **Figure 17**.

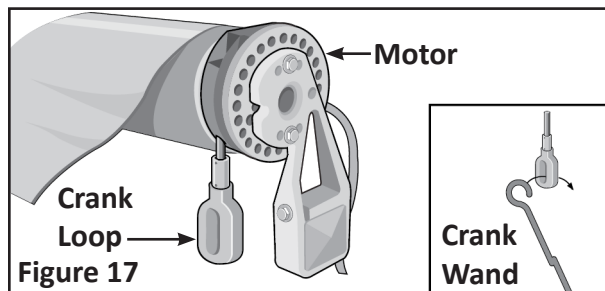

Test for Proper Operation

Note: When opening the Awning for the first time, the Motor will begin to open, quickly reverse direction closing all the way, then continue to open. This is a standard operation of the Motor after it has been without power for more than two (2) minutes.

Channel 1 is pre-set to operate your motorized Awning. See **Figure 18**.

Note: The Open and Close stop limits on the Awning Motor were set and tested at the factory prior to shipment. To change the Open and Close limits of the Motor, see **Appendix A**.

CAUTION: Do not allow the Awning to Open past the point where the Fabric sags and wraps under the Roller Bar. For 18', 19' and 20' Awnings with Acrylic Fabric only, it is important to not allow the Fabric to wrap around the Roller Bar, underneath, where it can tear on the Center Support.

39. Test the operation of your Awning by using the **Open** and **Close** buttons on your Remote Transmitter.

See **Figure 18**.

- **Press and release the OPEN button.** The Awning opens to its full projection and the arms will still be bent but locked at the elbow (**this is normal**). Press **my/STOP** to stop the Awning.
- **Press and release the CLOSE button.** The Awning closes to about ½” between the Front Bar and the round front edge of the Arm Clamp. See **Figure 25** on **Page 22**.
- Press **my/STOP** to stop the Awning at any position.

If your Awning fails to open to its full projection or does not appear to open and close properly, please follow the steps in **Appendix A** on **Page 22** to change the Open/Close Stop Limits.

40. VISTA Model Only:

Using the Crank Wand, open your Awning to its full projection.

- a. The Lateral Arms will still be bent but locked at the elbow (**this is normal**). They will never straighten out completely.
- b. The Fabric will remain tight between the Roller Bar and Front Bar when fully opened. If the Fabric sags, crank the Awning closed until the Fabric begins to pull the Front Bar closed and the Lateral Arms begin to bend, slightly. See the **CAUTION** above, regarding the maximum Open limit.

41. Are you happy with the height and level of the Front Bar?

If **yes**, Great! Your installation is now complete. Enjoy your new SunSetter Awning.

If **No**, and you would like to change the Pitch (angle) of your Awning, refer to **Appendix B** on **Page 23**.



The Multi-Channel Remote Transmitter

Your Motorized Awning is programmed at the factory to respond to Channel 1 on the Multi-Channel Remote Transmitter packaged with your Awning.

Each Channel on every Multi-Channel Remote Transmitter (see **Figure 19**) has a unique ID (identification code) that allows your Remote to act as five (5) different Remote Transmitters.

The first LED light on the left is Channel 1. Press and release the Channel Selector Button to display a blinking LED Light on the active Channel.

To change the active Channel, press the Channel Selector Button while the LED light is blinking. The next Channel LED light will blink, making that the active Channel. Repeat pressing the Channel Selector Button to move from Channel 1 through Channel 5 (all 4 LEDs blink).

The Motor in your Awning can be programmed to respond to any or all of the 5 Channels of the Multi-Channel Remote Transmitter.

Notes:

- **Each Channel can be added to any number of different Motors, so one Multi-Channel Remote can control multiple Awnings, independently.**
- **Multiple Channels or Remotes can be added to any one Motor. This way, the user can control the Awning from more than one Channel, on the same or on more than one Multi-Channel Remote Transmitter.**
- **If only one Channel operates the Motor, this one Channel cannot be deleted from the Motor's memory.**
- **Never use the same Channel to control your Motorized Awning and Dimming LED Light System. The UP arrow will CLOSE your Awning, but will also TURN ON your Dimming LED Light System. SunSetter recommends Channel 1 to operate the Awning and Channel 2 to operate your Dimming LED Light System.**
- **When programming multiple Motors and Remote Transmitters, always unplug all SunSetter products and plug in ONLY the one particular product you wish to program for the Remote, at that time. This simplifies the process and reduces errors regarding which Remote operates which product.**

The Programming Button inside the small opening on the back of the Remote Transmitter is used to **ADD** or **DELETE** individual channels from the Motor's memory.

1. To **ADD** a channel, such as Channel 2, 3, 4, or 5 to control the Motor:
 - a. Activate Channel 1 of the Remote Transmitter.
 - b. Press and Hold the Programming Button in the back of the Remote until the Awning jogs or moves slightly.
 - c. Press the Channel Selector Button to move the active Channel to the Channel you want to use to control your Motorized Awning.
 - d. Press and Hold the Programming Button in the back of the Remote until the Awning jogs or moves slightly.
 - e. This active Channel has been added to the Motor's memory.
2. To **DELETE** a Channel that controls your Awning's Motor:
 - a. Select the Channel you wish to keep controlling your Awning's Motor or LEDs.
 - b. Press and Hold the Programming Button in the back of the Remote until the Awning jogs or moves slightly (or LEDs blink).
 - c. Press the Channel Selector Button to move the active channel to the channel you want to delete from the control your Awning or LEDs.
 - d. Press and Hold the Programming Button in the back of the Remote until the Awning jogs or moves slightly (or LEDs blink).
 - e. This active Channel has been DELETED from the Motor's (or LED's) memory.

Note: The steps to **ADD** are the same as **DELETE**. They simply "toggle" whether the Remote controls the Motor or does not control the Motor.

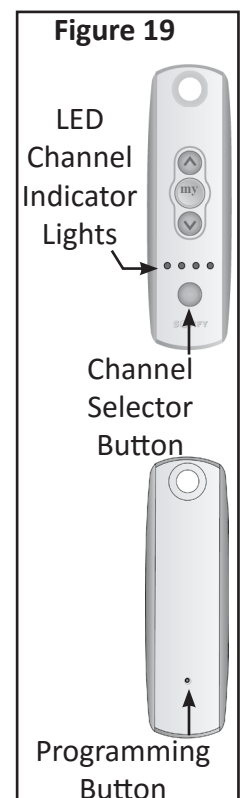

General Care and Maintenance of Your SunSetter Awning

WARNING: PRIOR TO OPERATING THE AWNING, BE SURE THAT NO OBJECTS OR PERSONS CAN COME IN CONTACT WITH IT AS IT OPENS AND CLOSES. KEEP CHILDREN AWAY FROM ANY MOVING PARTS OF THE AWNING AS IT OPERATES. FAILURE TO DO SO COULD RESULT IN PERSONAL INJURY.

CAUTION: Never attempt to hang items from any part of the Awning, except those accessories that are supplied by the manufacturer.

WARNING: NEVER ATTEMPT TO REPAIR OR DISASSEMBLE ANY PART OF THE AWNING WITHOUT FOLLOWING REPLACEMENT PART PROCEDURES SUPPLIED BY THE MANUFACTURER. TRYING TO DO SO WITHOUT PROPER INSTRUCTIONS COULD RESULT IN PERSONAL INJURY.

CAUTION: Damage to the Awning Fabric, Arms and mechanism caused by water pooling or windy conditions are not covered by the manufacturer's warranty. **Always retract your Awning during periods of snow or heavy rain. Never leave your Awning extended out and unattended when there are heavy winds.**

WARNING: RAIN WATER POOLING ON THE FABRIC COULD RESULT IN DAMAGE TO, OR THE COLLAPSE OF THE AWNING AND CAUSE PERSONAL INJURY. YOU MUST ROLL UP YOUR AWNING WHEN WATER STARTS POOLING ON THE FABRIC. TO SAFELY DRAIN WATER THAT ALREADY POOLED ON THE FABRIC, FOLLOW PROCEDURES IN APPENDIX C ON PAGE 25.

Note: It is normal for the Fabric to form waves or wrinkles at the hemmed edges as the Awning rolls up. This is because the Fabric layer is double only along the edges. It is also possible for the Awning Fabric to sag as a result of its own weight, this is normal.

PROTECTING THE SUNSETTER LAMINATED FABRIC FROM MILDEW

If it is necessary to roll the Awning up wet, be sure to extend it out to dry when the weather is better. While the Awning Fabric itself won't mildew, note that mildew can form on the dust and dirt allowed to accumulate on the Fabric. If the Fabric is rolled up and stored when wet, the moisture will promote the formation of mildew. Do not use caustic cleaners.

CLEANING THE LAMINATED FABRIC

Cleaning the Awning regularly with mild soap and water will extend the life of the Fabric and prevent the formation of mildew. Call **800-670-7071** to order a SunSetter Cleaning and Maintenance Kit.

PROTECTING THE SUNSETTER FRAME

Your SunSetter Awning contains extruded and die-cast aluminum components. These aluminum parts are powder-coated for long lasting beauty. (We have included a bottle of color-matched touch-up paint with your Awning in the event that some area of the painted surface gets scratched during installation. Please use it as needed.)

LUBRICATION

Once a year, you may wish to lubricate **the gray plastic bushing on the Roller Bar** on the side opposite of the Motor or gear crank unit. During extended use, dust may accumulate on this moving part and may cause a minor squeak as the Awning opens or closes. **Any type of light lubricant** will eliminate this type of noise. You may also wish to lubricate the pivot point of the Lateral Arm Elbows. See **Figure 16** on **Page 13**.

The **plastic handles of the Crank Wand** can be lubricated with a small amount of **light lubricant**, to address squeaking that could occur.

WARNING: NEVER USE A BARBECUE GRILL, ANY TYPE OF PATIO HEATER OR FIREPLACE UNDER YOUR SUNSETTER AWNING. DOING SO COULD RESULT IN THE FABRIC BURNING OR MELTING AND COULD RESULT IN PERSONAL INJURY.

See **Figure 20**.

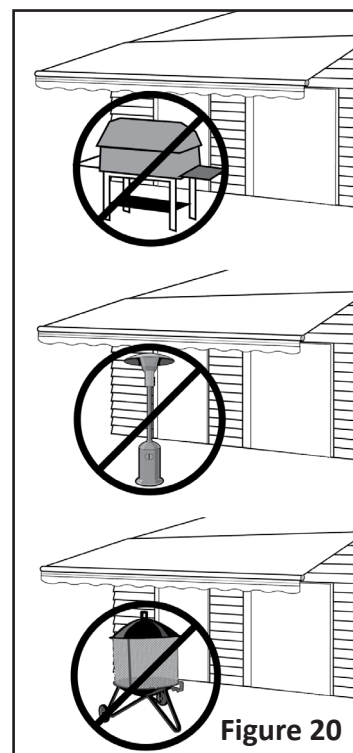

Figure 20

Care and Maintenance - SunSetter Woven Acrylic Fabrics

SunSetter woven acrylic Fabrics are made of 100% solution-dyed acrylic fiber and have a special finish which delays the formation and accumulation of dirt. To preserve this finish, cleaning of the fabric must include the following.

Standard Maintenance

- Thoroughly remove the dust from the dry Awning Fabric by vacuum cleaning, gently beating or brushing.
- Then clean with a prolonged spraying of lukewarm water and a mild soap while gently brushing. Rinse thoroughly to remove soap.

Stain Removal

For more stubborn cases, a general solution of no more than ½ cup (4 oz.) of bleach and ¼ cup (2 oz.) of mild soap per gallon of water is normally recommended. Do not leave this mixture on the Fabric for more than 20 minutes. Then the Fabric should be rinsed thoroughly with cold water to remove all of the mixture.

CAUTION: Bleach can deteriorate sewing threads. The Fabric should be rinsed thoroughly with cold water to remove all of the soap. This method of cleaning may remove part of the water repellency of the Fabric. Therefore, if water repellency is important, the Fabric afterwards should receive an application of any air-curing fluorocarbon water repellent treatment, such as 303 High Tech Fabric Guard.

Applying 303 High Tech Fabric Guard

303 Should be applied to SunSetter woven acrylic Fabrics after each thorough cleaning, which typically removes the original finish and reduces the Fabric's water repellency.

- Allow the clean Fabric to completely air dry.
- Apply 303 Fabric Guard in a well ventilated area following instructions on the container.
- Apply 303 in a thin, even coat and allow Fabric to dry completely.
- Apply a second thin, even coating of 303. (Two light coatings are more effective in restoring Fabric water resistance than a single heavy coating. A 15 ounce bottle provides coverage of up to 50 square feet of fabric).

For more information please see www.303products.com.

CAUTION: If an Awning is retracted while wet, open it as quickly as possible and allow the Fabric to dry. Although the Fabric is mold, mildew and rot resistant, this procedure is necessary because atmospheric pollution deposits on the surface of the Fabric can mold and mildew under damp conditions.

Care and Maintenance of Your Electric Motor and Remote Transmitter

WARNING: ANY PERMANENT WIRING OF THE AWNING MUST BE PERFORMED BY A LICENSED ELECTRICIAN PER YOUR LOCAL ELECTRICAL CODES. FAILURE TO DO SO COULD RESULT IN PERSONAL INJURY.

The Outdoor Electric Motor

The Motor is supplied by Somfy Systems Inc., the recognized world leader in specialized electric tubular motors for Awnings and sunshades. This 110 volt Motor is **UL** (Underwriters Laboratories) and **CSA** (Canadian Standards Association) approved. This Somfy Motor features the manual override option that allows you the safety and convenience of manual operation during electrical failures.

The electric Motor is equipped with an **automatic overheat protection shutoff system**. If you run your Awning several times continuously, the Motor will stop its operation before it overheats. The Motor will resume normal operation after **15 minutes** of cooling down.

Protecting the Outdoor Electric Motor from Water Damage

To prevent water from entering the head of the Motor, it is recommended that a **Drip Loop** be formed as shown in **Figure 21**. **Notice that the bottom of the loop is lower than the cord's entry point to the Motor.** Rain water gaining access into the Roller Bar could damage the internal components of the Motor. If your Awning is not installed under an overhang, we strongly recommend that you call Customer Service at **800-670-7071** and purchase the SunSetter Awning Cover or Aluminum Hood.

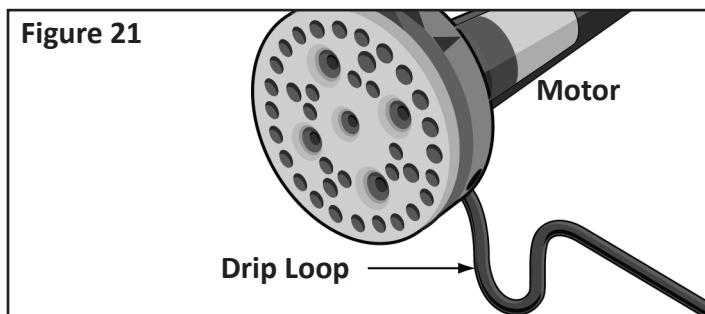

Protecting the GFI Electrical Outlet from Water Damage When Motor Power Cord is Plugged In

To prevent water from entering the (GFI) Wall Outlet it is recommended that a **Drip Loop** be formed at the end of the Power Cord as shown in **Figure 22**. Additionally, it is recommended that an "In-Use Weatherproof Cover" is installed over the Outlet. Covers are available at most local hardware stores.

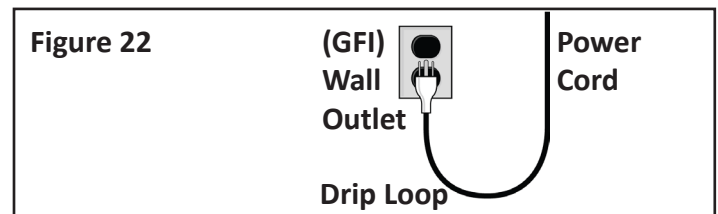

Preparing Your Awning for Winter

Unplugging the Motor Power Cord from your (GFI) Wall Outlet and covering the socket may prevent rain and moisture from entering the outlet which could interfere with proper Motor function in the Spring. Before rolling up your Awning for the last time of the season, it may be beneficial to ensure the Fabric is clean and dry which will prevent mildew from forming over the winter. If your Awning is not installed under an overhang, and to aid in Winter protection we strongly recommend the use of a SunSetter Awning Cover or Aluminum Hood. To order one please call Customer Service at **800-670-7071**. The Valance may be removed for winter storage, by sliding it out of the Valance Slot in the Front Bar.

Changing the Battery in Your Remote Transmitter

Please note that you might have to replace the battery after 3 years, or if the Remote Transmitter stops working.

Test the Remote Transmitter by holding a button down. The LED should flash for at least 5 seconds.

You should find this type of battery (**3V Lithium CR2430**) in any local hardware store. To replace the battery, simply remove the small Phillips screw on the back of the Remote Transmitter, remove the back cover, replace the old battery and reinstall the back cover and Phillips screw. Be sure to note the orientation of the old battery as you remove it.

TROUBLESHOOTING

| Problem with Installation | Solution |
|---|---|
| Can I “hard-wire” the Awning Motor into my home? | SunSetter cannot be responsible for any changes in electrical configuration of the Motorized Awning. Have your electrician contact Somfy (motor manufacturer) directly via their website www.somfysystems.com . Do not cut the cord within 2’ of the Motor connection. Note: Some maintenance procedures such as resetting communication between the Remote Transmitter and Awning require power to be interrupted. Therefore, hard-wiring the Awning may interfere with this procedure. |
| How low can the pitch be set? | As low as 45 degree angle. See procedure in Appendix B . |
| How high can the pitch be set? | Pitch is factory set for the Front Bar to be 29” lower than the top of the Roller Bar. See Figure 3 on Page 7 . If you reach the maximum adjustment and are still not happy with the height of the Front Bar, you can shim the Wall Brackets upward to raise the Front Bar further . Make sure that all Wall Brackets are shimmed evenly. See Appendix B for pitch adjustment instructions. |
| When I first press the button to operate the Awning, it moves open, then closes on its own and then opens correctly. | When the Awning is plugged in the first time, and anytime the Motor has been without power for more than two (2) minutes , the next command will cause the Awning to open several inches, close all the way, then the Awning will continue to open. This is a normal function. If the Awning is plugged in to a switched outlet, this will occur after power has been interrupted for more than two (2) minutes, then restored, when the Awning is next used. |
| Problem with Appearance | Solution |
| Fabric wrinkles when the Awning is opened or closed. | The Awning Fabric has a hem along both ends of the material; some wrinkling is a characteristic of the extra thickness along either edge. This wrinkling may be more noticeable when retracted and after prolonged periods when the Awning is not used. This condition is normal. Leaving the Awning open in warm weather should minimize the wrinkling over a period of time. Ensuring that the Awning Fabric is centered on both the Roller Bar and the Front Bar may also lessen the appearance of wrinkles in the Fabric. |
| Lateral Arms (elbows) are not even when the Awning is retracted. | This is generally caused by Fabric not centered on the Roller Bar and/or the Front Bar. See the steps below for centering Fabric on the Roller Bar and Front Bar. |
| Lateral Arms do not fold evenly. Lateral Arms may bang against the Square Bar or extend beyond the Front Bar, or Fabric gathers more to one side (telescoping fabric) on the Roller Bar as the Awning retracts. or Fabric is not centered on the Roller Bar or the Front Bar. | This procedure works best with helpers . <ol style="list-style-type: none"> 1. Open the Awning all the way. 2. Unplug the power cord from the outlet. 3. Mark the Roller Bar (using pencil or tape) with the left and right positions of the Fabric. 4. Note which Lateral Arm closes closest to the house or bangs on the Square Bar. 5. Using the Crank Wand, open the Awning; continue until the Roller Bar is fully exposed. 6. Slightly move the Fabric in the direction of the Lateral Arm noted in number 4. 7. Two people hold the Fabric in place on the Roller Bar, while the third person manually cranks the Awning closed until the Fabric is tight and the Front Bar begins to close. 8. Plug in the power cord and close the Awning. 9. Watch how the Arms close, particularly in the last couple feet of the Awning closing. 10. Repeat the Fabric adjustment, a half inch at a time at the Roller Bar, as needed. 11. If problems persist, please call Customer Service at 800-670-7071 for support. |
| The Roller Bar and Fabric appear to bounce when opening and closing the Awning. | The Roller Bar that holds the Fabric is supported only at the extreme ends and it bows slightly toward the center. As the Roller Bar rotates, it may move up and down toward the center. This is a natural tendency of the bar and may be more noticeable with larger sized Awnings. |
| My Fabric is rubbing against the Arm Clamps when it is opening/closing. | The Fabric should not come in contact with the hardware when it is opening or closing. Verify the Fabric is rolling over the top of the Roller Bar (see Figures 23 & 24 on Page 22). The Fabric should be taught between the Roller Bar and Front Bar when the Awning is fully Open. If Fabric sags, the Open stop setting may need to be adjusted closer to the house. |
| The VISTA Awning Drive Unit binds, skips, or spins freely. | The Drive Unit gears may have been stripped or damaged during operation. Please call Customer Service at 800-670-7071 for assistance and possible replacement of the Drive Unit. |
| Squeaks | The plastic handles of the Crank Wand may be lubricated with a small amount of light lubricant, to address squeaking that may occur. For more information, see the LUBRICATION section on Page 16 . |

TROUBLESHOOTING - Continued

| Problem with Motor or Gear Assembly | Solution |
|--|---|
| After installing, the Awning will not function. | <ul style="list-style-type: none"> • Is the Remote Transmitter set to Channel 1 (1st LED light on left), as preset at the factory? • Is there power to the outlet? Test with a known good appliance, such as a lamp. • Test the Remote Transmitter - Hold a button, the LED light should blink for at least 5 seconds. • If Remote Transmitter fails this test, replace the battery (CR2430) with a new battery. |
| The red LED light on the Remote Transmitter does not come on when I press and hold a button. | <ul style="list-style-type: none"> • Remove the battery and reinsert (check polarity to ensure battery is inserted correctly) in battery slot and try pushing button again, if no light, replace battery. • To replace the battery (CR2430) see “Changing the Battery” on Page 18. |
| The Awning closes on its own. | <p>Three conditions can cause the Awning to close on its own.</p> <ol style="list-style-type: none"> 1. The Wireless Wind Sensor has detected rapid movement up and down and has sent a “close” signal to the Awning, causing the Motor to close the Awning. The sensitivity of the Wireless Wind Sensor is set inside the device. The sensitivity is adjusted by using a small screwdriver to turn the potentiometer from the factory setting of 2 to a higher setting up to 9. When setting the Wind Sensor to be more sensitive, the setting can be set as low as 1. 2. Every 15 minutes = The Wireless Wind Sensor has low batteries, causing the Motor to Close the Awning. Change the AAA batteries. Do not use rechargeable batteries. 3. Every 60 minutes = The Wireless Wind Sensor has lost communication with the Motor. This can be caused by dead or incorrectly inserted batteries, in which case the AAA batteries must be replaced (use non rechargeable batteries). This can also be caused by a Wind Sensor being physically removed from the Awning without removing it from the Motor’s memory. <p>For more information, please see the Wireless Wind Sensor Installation Instructions.</p> |
| Awning works in one direction only. | Follow instructions in Appendix A to see if the preset Open or Close stop position setting can be adjusted. If this fails, please call SunSetter Customer Care at 800-670-7071 for assistance. |
| The Open or Close stop limit needs to be changed. | Follow instructions in Appendix A to change existing Open or Close stop limits of the motor. Appendix A requires the Awning stop on its own at the setting to be changed. If the Awning cannot reach the Open limit due to an obstruction such as a tree or structure, follow the instructions in Appendix D to completely remove and recreate new stop position limits. |
| Can other Remote Transmitters interfere with the operation of this motor? | No. Your Somfy Sunea motor operates on a specific frequency. In addition, each Remote Transmitter has its own unique identification code that must be manually and intentionally matched to each motor. |
| Can more than one Somfy Remote Transmitter control my Awning? | Yes. Your Somfy Sunea motor can be programmed by you to accept commands from multiple controllers such as the Wireless Wall Switch, Wireless Wind Sensor, All Weather Remote Control, and other Remote Transmitters. See Appendix D to add or delete additional Control Devices. |
| Motor stopped responding, but worked a few minutes ago. | The motor is enclosed inside the Roller Bar. Heat can become trapped inside the Roller Bar, causing the motor to overheat and turn itself off after several minutes of continuous use. This may occur in as few as 5 to 10 cycles of opening and closing the Awning. This may be more noticeable with the wider model and XL Awnings, particularly in hot weather. Please allow at least 15 minutes for the motor to cool down before attempting to operate the motor again. Meanwhile, you can open or close your Awning using the supplied Crank Wand. |
| The GFI outlet ‘trips’ or shuts off. | <ul style="list-style-type: none"> • Test the outlet by plugging in another appliance (such as a hair dryer or lamp) to ensure the outlet is working properly. • Test the Awning by getting power from an outlet on another circuit using an extension cord. • There may be moisture inside the motor housing causing the GFI to trip, please allow the motor to dry out over 2-3 days. The motor is designed to operate if it gets wet and dries out. • Installing the SunSetter Cover or Aluminum Hood over your Awning will reduce the risk of rain water affecting the operation of the Motor. • If Motor is wet, use a drip loop on the power cord as shown in Figures 21 and 22 on Page 18. |
| Button on Remote Transmitter must be held down for Awning to Open or Close. | The Motor is not in User Mode. Follow the steps in “ Additional Motor Troubleshooting ” on Page 21 to return the Motor to User Mode in which “one-touch operation” returns. |

TROUBLESHOOTING - Additional Motor Troubleshooting

| Problem with Motor | Solution |
|--|--|
| <p>Awning / Motor Does Not Respond to Remote Transmitter Properly <i>(First, verify that electric power is good and Remote Transmitter passes Self Test as described in the section below)</i></p> <p>or</p> <p>Awning / Motor only runs while holding down the UP or DOWN button on the Remote.</p> | <ol style="list-style-type: none"> 1. Unplug Motor, 2. Wait two seconds, 3. Plug in Motor, 4. If Motor jogs, go to Section A, 5. If Motor does not jog, go to Section B. <hr/> <p>Section A</p> <ol style="list-style-type: none"> 1. Press and Hold the CLOSE and OPEN buttons together, on the Remote Transmitter. 2. Hold until Motor jogs or moves. 3. Press and Hold the PROGRAMMING button. 4. Hold until Motor jogs or moves a little bit. <p>5. TEST for proper operation.</p> <hr/> <p>Section B</p> <ol style="list-style-type: none"> 1. Press and Hold the CLOSE and OPEN buttons together, on the Remote Transmitter. 2. Hold until Motor jogs or moves. 3. Perform Steps 9 - 18 in Appendix D on Page 26. <p>4. TEST for proper operation.</p> <hr/> <p>If Section A or B (above) does not fix the problem, then . . .</p> <p>Perform Steps 1 - 18 in Appendix D on Page 26, or call SunSetter Technical Support at 800-670-7071.</p> |
| <p>How to Self Test the Remote Transmitter</p> | <ol style="list-style-type: none"> 1. Press each button (CLOSE, OPEN, my) on the front of the Remote Transmitter, one at a time. 2. Hold each button for 5 to 10 seconds. 3. LED light should blink for at least 5 seconds, then stop blinking. 4. If Steps 1 - 3 work, the Remote Transmitter is good. 5. If this fails, replace the Remote Transmitter's Battery with a new Lithium CR2430. See Page 18. |

APPENDIX A

ADJUSTING THE OPEN AND CLOSE STOP LIMITS FOR THE SUNSETTER MOTORIZED AWNING

If a preset Open or Close stop position needs to be changed, but the Awning cannot stop automatically at that position, possibly due to an obstruction such as a tree or shed being in the way, then see Appendix D on Page 26 to clear the motor of preset stop positions and set new Open and Close stop positions.

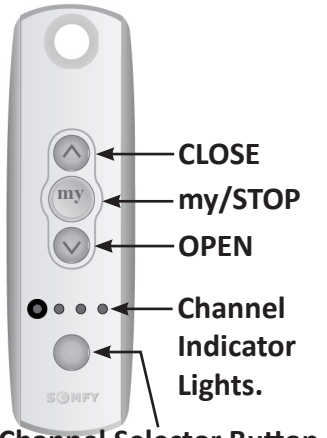

Channel Selector Button.

- Press to identify active Channel.
- Press while light blinks to change Channel.

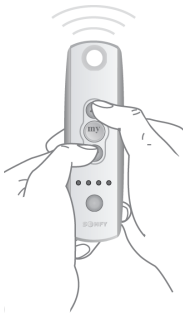

TO CHANGE THE OPEN LIMIT:

1. Select the correct Channel. The Remote was preset to operate on Channel 1.
2. Open the Awning to its current Open position and **let it stop on its own.**
3. Press and Hold the OPEN (down arrow) and CLOSE (up arrow) buttons simultaneously until the Awning moves a little bit, or jogs back and forth, then release the buttons.
4. Adjust the Awning to the new Open limit position. The awning moves only while pressing the OPEN (down arrow) or CLOSE (up arrow) button.
5. Press and Hold the “my” (my button) button until the Awning moves a little bit, or jogs back and forth, then release the “my” (my button) button.
6. Check the new Open limit.

TO CHANGE THE CLOSED LIMIT:

1. Close the awning to its current Closed position and **let it stop on its own.**
2. Press and Hold the OPEN (down arrow) and CLOSE (up arrow) buttons simultaneously until the Awning moves a little bit, or jogs back and forth, then release the buttons.
3. Adjust the Awning to the new Closed position. The awning moves only while pressing the OPEN (down arrow) or CLOSE (up arrow) button.
4. Press and Hold the “my” (my button) button until the Awning moves a little bit, or jogs back and forth, then release the “my” (my button) button.
5. Check the new Closed limit.

OPEN POSITION

When Open, the Lateral Arms are slightly bent and the Fabric is snug.

The Fabric should be rolling over the top of the Roller Bar (see Figure 23), not underneath (See Figure 24). If the Fabric is rolling from the bottom of the Roller Bar, continue unrolling the Fabric until it rolls over the top of the Roller Bar. Then roll up the Fabric until both the Lateral Arms bend slightly and Fabric becomes tight.

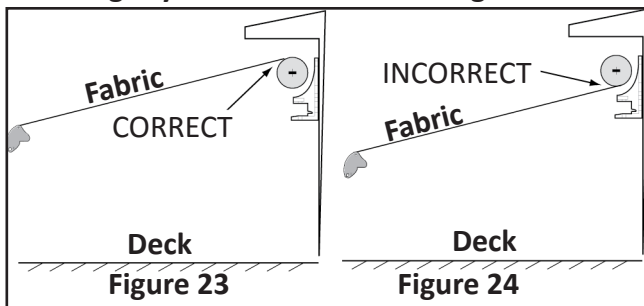

CLOSE POSITION

The Awning should close to about 1/2" between the Front Bar and the Arm Clamps. See Figure 25.

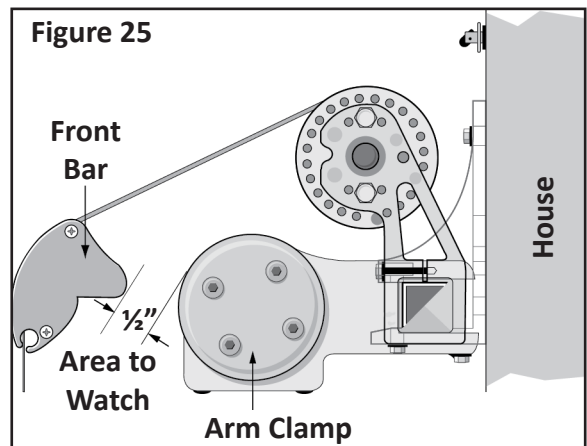

APPENDIX B - Changing the Pitch of Your Awning

Tools Needed: 6mm Allen wrench (included with Awning), step ladder(s), and a helper(s).

Follow these instructions to change the pitch or angle (see **Figure 26** on **Page 24**) of your Awning.

Note: A Visual Guide is available on the Installation DVD and on the Owner's Corner.

1. Close the Awning.
2. Lift the Front Bar to remove pressure, and **tighten the 4 Allen cap bolts** in the Arm Clamp. See **Figure 27 insert** on **Page 24**.

Note: If you have a 10' Awning, you may need to temporarily remove the Override Crank from the Motor or the Crank Loop from the Gear Unit to allow easy access to the Allen cap bolts. Simply reinstall the Override Crank or Crank Loop when you are done.

3. Open the Awning.
4. Loosen all 4 Allen cap bolts, **not more than one turn**. See **Figure 27 insert** on **Page 24**.

To raise the Front Bar, complete steps 5 - 7:

WARNING: RAISING THE FRONT BAR WILL REDUCE THE PITCH (ANGLE) OF THE FABRIC THUS INCREASING THE RISK OF RAINWATER POOLING ON THE FABRIC. TO PREVENT THE AWNING FROM COLLAPSING DUE TO RAINWATER LOAD, YOU MUST RETRACT THE AWNING WHEN UNATTENDED. FAILURE TO DO SO COULD RESULT IN PERSONAL INJURY.

5. Lift the Front Bar and loosen **Set Screw #1** until the Front Bar is above the desired height. See **Figure 27 insert** on **Page 24**.

6. While holding up the Front Bar above the desired height, tighten Set Screw #2.

Note: Setting the Front Bar above the desired height allows room for settling when you release the Front Bar.

7. Tighten **Set Screw #1**.

Go to Step 10.

To lower the Front Bar, complete steps 8 - 9:

8. Lift the Front Bar to remove pressure, and loosen Set Screw #2 until the Front Bar can reach the desired height. See **Figure 27 insert** on **Page 24**.

9. Tighten **Set Screw #1**.

Go to Step 10.

10. Let the Front Bar hang on its own.

11. Tighten all 4 Allen cap bolts. See **Figure 27 insert** on **Page 24**.

12. Push the Front Bar down. If it moves from the desired height, repeat the steps above.

Note: Depending on the Awning size and model, the weight of the Front Bar varies (Example: Wider Awnings will have heavier Front Bars). This will impact how high you can raise the Front Bar, using the adjustment capabilities of the Arm Clamps. If you reach the maximum adjustment and are still not happy with the height of the Front Bar, you can shim the Wall Brackets upward to raise the Front Bar further. Make sure that all Wall Brackets are shimmed evenly.

Note: Depending on adjustments, the Open/Close position stops may need to be adjusted to correct any sagging that may occur to the Fabric. Follow the procedures in Appendix A to change these settings.

You are now done with the installation. If you purchased a Motorized Awning, plug the power cord into the (GFI) outlet and enjoy your Awning.

APPENDIX B (Continued) - Changing the Pitch of Your Awning

Figure 26 Pitch is set at factory so Front Bar is 29" lower than the top of the Fabric on the Roller Bar.

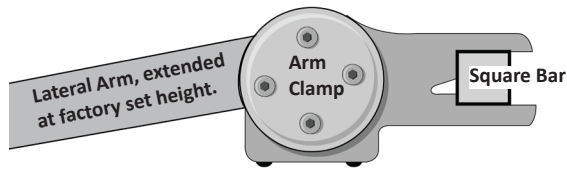

Pitch raised to maximum height.

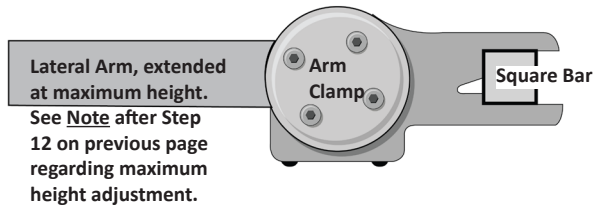

Figure 27

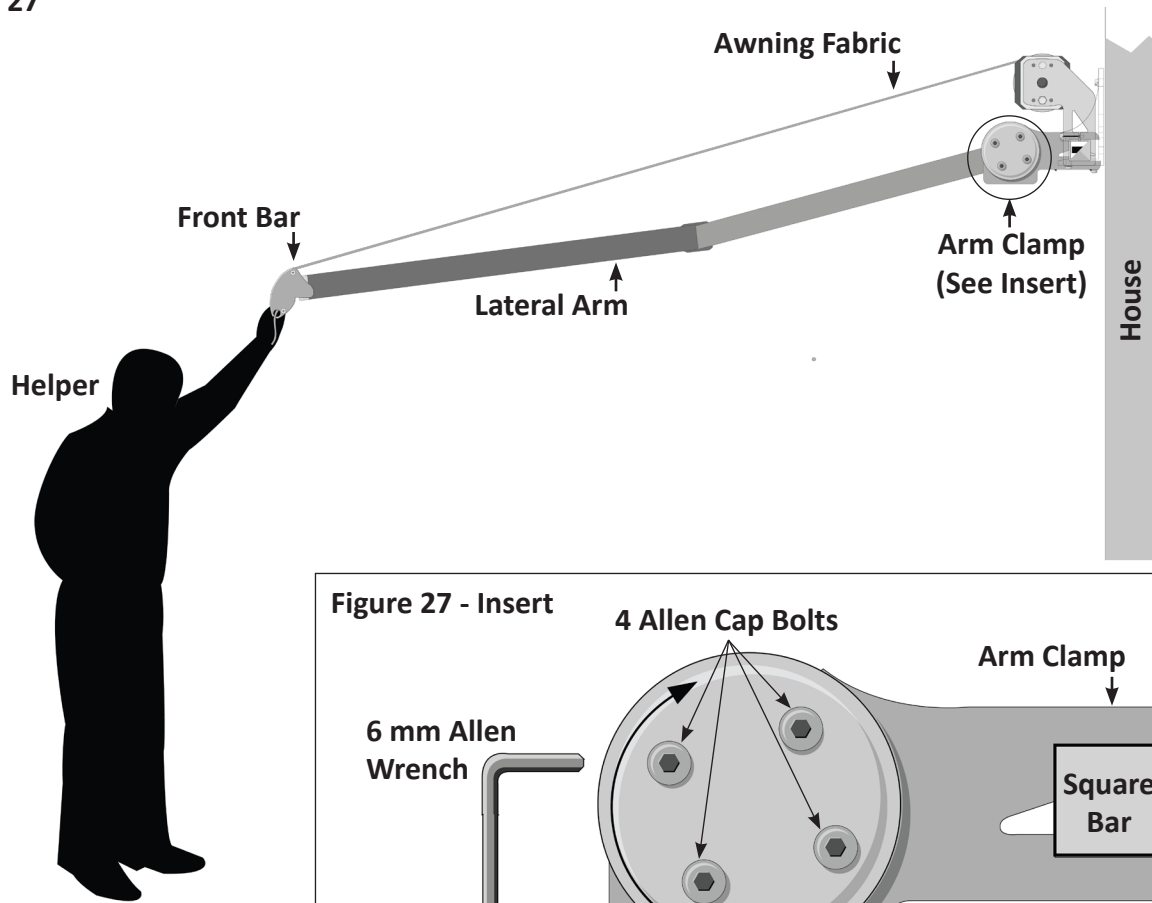
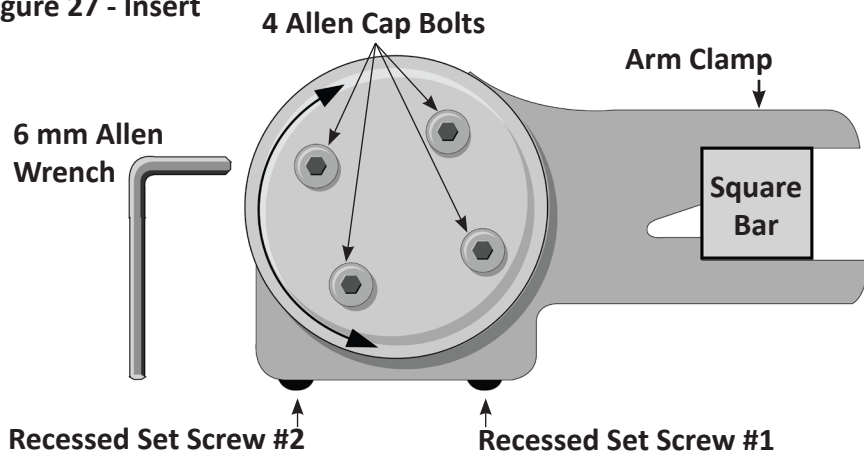

Figure 27 - Insert



APPENDIX C

How to Drain Water From Your Awning Fabric

WARNING: THE SUNSETTER AWNING IS NOT DESIGNED TO HOLD THE WEIGHT OF RAINWATER POOLING ON THE FABRIC. ACCUMULATION OF RAINWATER ON THE FABRIC COULD COLLAPSE THE AWNING AND CAUSE SERIOUS INJURY!

If, for any reason, rainwater accumulated on the fabric, follow the instructions below to remove the water. **You will need a helper for this procedure.**

WARNING: NEVER WALK UNDER AN AWNING WITH WATER ACCUMULATED ON THE FABRIC! THERE COULD BE A TREMENDOUS AMOUNT OF WEIGHT ON THE AWNING AND THE FRAME COULD COLLAPSE AT ANY MOMENT AND CAUSE SERIOUS INJURY!

1. Connect a common garden hose to your outside water faucet.
2. While standing in front of the awning (**BUT NOT UNDER THE AWNING**), visually observe where is the deepest point of the water pooling on the fabric.
3. Hold the open end of the garden hose about head high. **DO NOT ALLOW ANY WATER TO RUN ONTO THE FABRIC.**
4. Have a helper turn the water faucet on. Let water run **ONTO THE GROUND** until there is a solid stream of water.
5. Continue to hold the end of the hose head high and have your helper turn the water **OFF**. Leave the hose connected to the faucet.
6. Place the end of the hose over the front of the awning and let the open end of the hose slide into the deepest point of the water pool. **DO NOT GO UNDER THE AWNING!**
7. While the open end of the hose is **UNDER THE SURFACE OF THE WATER**, have your helper disconnect the water hose from the faucet and lay it on the ground.
8. The siphon caused by the water running out of the hose will drain the water from your awning. Let the water continue to drain until the flow of the water through the hose stops.
9. While keeping the end of the hose submerged, move it around on the fabric to keep it under the surface of the water to fully drain the water from the fabric.
10. When the drain stops, make sure most of the water was drained. If not, repeat the process until most of the water is drained off of the fabric.
11. Close the awning and let the rest of the water run off totally from the fabric.
12. Inspect your awning for damaged parts, and check for normal operation.

APPENDIX D

Resetting Remote Communication and Reprogramming the Motor

This procedure will completely reset the communication between the Remote Transmitter and Motor, as well as erase and reprogram the **Open** and **Closed** stop position settings of the Motor.

This procedure programs the Awning Motor to accept commands from one primary Remote Transmitter.

This procedure overwrites the factory set **Open** and **Closed** positions with new **Open** and **Closed** positions.

Note: To **ONLY** change the **Open** and **Close** preset positions, follow the procedure in Appendix A on Page 22.

Tools needed: A pen or similar pointing device is needed to press and hold the Programming Button.

WARNING: ALL STEPS MUST BE FOLLOWED EXACTLY AND COMPLETELY.



PREPARE MOTOR - Read these instructions FIRST, completely and thoroughly

1. Set the Remote Transmitter to Channel 1 (for single channel Remote, skip this step).
2. Press and Hold the **my** button; the red LED light should blink for at least 5 seconds.
3. Disconnect Power for two (2) full seconds.
4. Connect Power for ten (10) full seconds.
5. Disconnect Power for two (2) full seconds.
6. Connect Power. The Awning should move, then stop on its own.
7. Press and hold the **Programming** button for ten (10) seconds, watching for two (2) separate jogs back and forth, several seconds apart.

Note: A single jog is defined as a quick two-direction movement of the motor.

8. Press and Hold the **CLOSE** and **OPEN** buttons together, release when the Awning jogs.
Note: The Awning now moves **ONLY** while holding down the **CLOSE** or **OPEN** button.

SET PROPER DIRECTION OF MOTOR ROTATION

9. Press the **OPEN** button to check the direction of the motor.
The fabric should **roll from the top** of the Roller Bar, opening the Awning.
10. If the direction is incorrect, change direction by holding the **my** button until the motor jogs. Press the **OPEN** button again to check for the correct direction of the motor rotation.

SET THE CLOSED AND OPEN POSITIONS

11. Move the Awning to the desired **Closed** position.
12. Press and Hold the **my** and **OPEN** buttons together; release when the Awning begins to **Open**.
13. Press the **my** button to **Stop** the Awning at the desired **Open** setting.
14. Make desired adjustments to the **Open** position.
15. Press and Hold the **my** and **CLOSE** buttons simultaneously; release them when the Awning begins to **Close**. **Let the Awning stop on its own** at the **Closed** position set in step 11.
16. Press and Hold the **my** button; release when the Awning jogs. This step stores the new **Open** and **Close** positions.

Note: If steps 8 - 15 fail, unplug the Awning, plug it back in, then begin again from step 8.

FINALIZE PROGRAMMING OF MOTOR

17. Press and Hold the **Programming** button; wait for a jog. This completes the procedure.
Note: The Awning now operates with a touch and release of the **OPEN** or **CLOSE** button.
18. Test the Awning for correct one-touch operation, using the **OPEN** and **CLOSE** buttons.



To Add or Delete a Control Device (Transmitter)

To **ADD** an additional Control Device (such as another Remote or Channel, or a Wireless Wall Switch);

- Press the Programming button on the back of the Transmitter that was supplied with the Awning until the motor “jogs.”
- On the additional Control Device, press the Programming button until the motor “jogs,” then release.

To **DELETE** a Control Device, repeat the two steps listed above and the additional Control Device is removed.

APPENDIX E - Front Roll Down Weatherbreaker

(Included with SunSetter Motorized Pro Model Only)

To open, insert the Crank Wand into the Crank Loop on the Front Bar (see Figure A). Turn the Crank Wand counter-clockwise to unroll the Weatherbreaker (see Figure B) to the desired position.

To close, turn the Crank Wand clockwise to roll-up the Weatherbreaker (see Figure C).

CAUTION: Remove the Crank Wand from the Crank Loop when not in use.

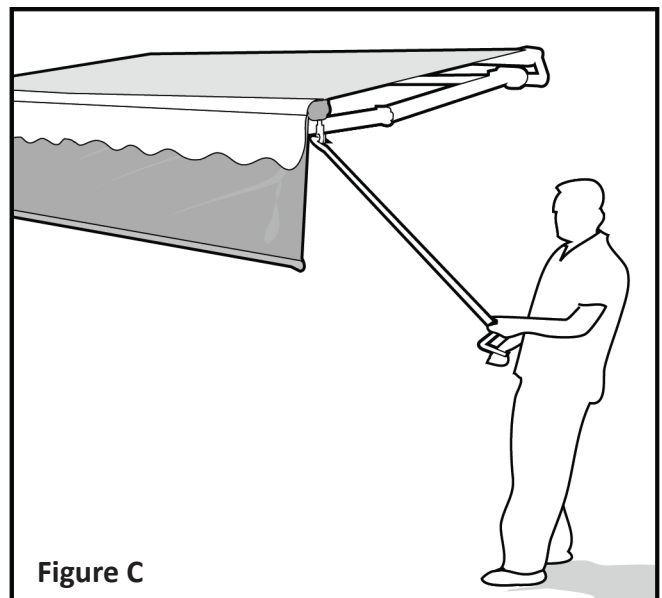
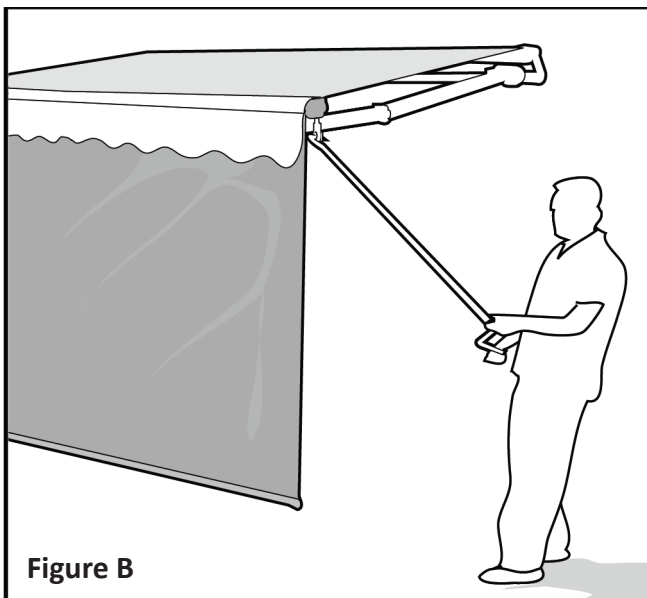
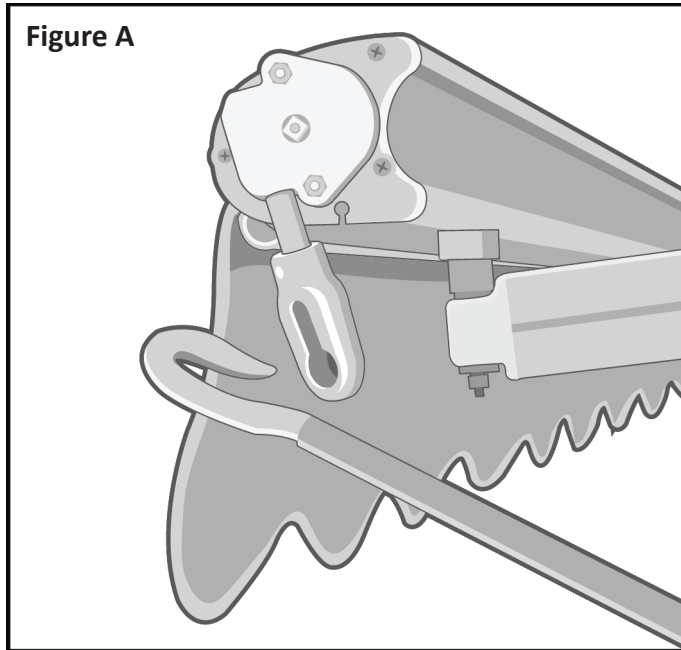

APPENDIX F

Awning Removal Procedure

Helper needed

Tools needed: ½" socket or wrench, ⅞" socket or wrench, ladders, (2) plastic safety sleeves

WARNING: FAILURE TO FOLLOW THESE INSTRUCTIONS COULD RESULT IN PERSONAL INJURY!

1. Close your Awning completely.
2. Unplug your Awning motor cord, if equipped.
3. Install your **Plastic Safety Sleeves** on both Lateral Arms to prevent them from extending. See **Figure 28**. If you do not have the Safety Sleeves that were supplied with your Awning, call **800-670-7071** for replacement Safety Sleeves that will be supplied free of charge.

WARNING: DO NOT ATTEMPT TO REMOVE THE AWNING WITHOUT INSTALLING THE PLASTIC SAFETY SLEEVES ON BOTH LATERAL ARMS.

4. Using a ½" socket or wrench, check that all 8 fasteners are tight, on the right and left side of the Awning (Arm Clamps - 2 each, Roller Brackets - 1 each, and Front Bar Connectors- 1 each). See **Figure 29**.
5. For Motorized Awnings- Using a ⅞" socket or wrench, check that the 2 bolts that secure the Motor to the Roller Bracket are tight. See **Figure 29**.
6. While your Helper keeps the Awning in the Mounting Brackets, carefully remove the Retaining Bolts, Nuts and Washers from each Mounting Bracket (Soffit or Wall). See **Figure 29 - Insert**.
7. Using the appropriate help, carefully remove the Awning from the Mounting Brackets and place on a stable surface.

CAUTION: Be careful not to drag the Awning on any surface as you can damage the Fabric or painted surfaces.

Figure 28

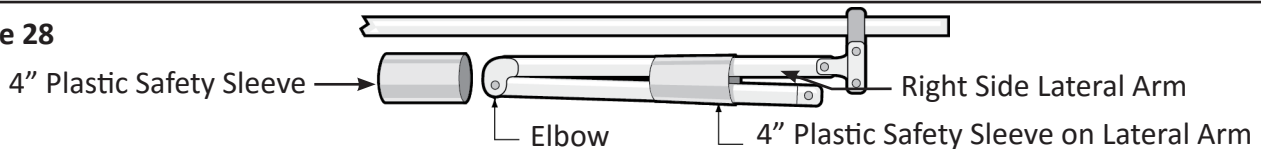
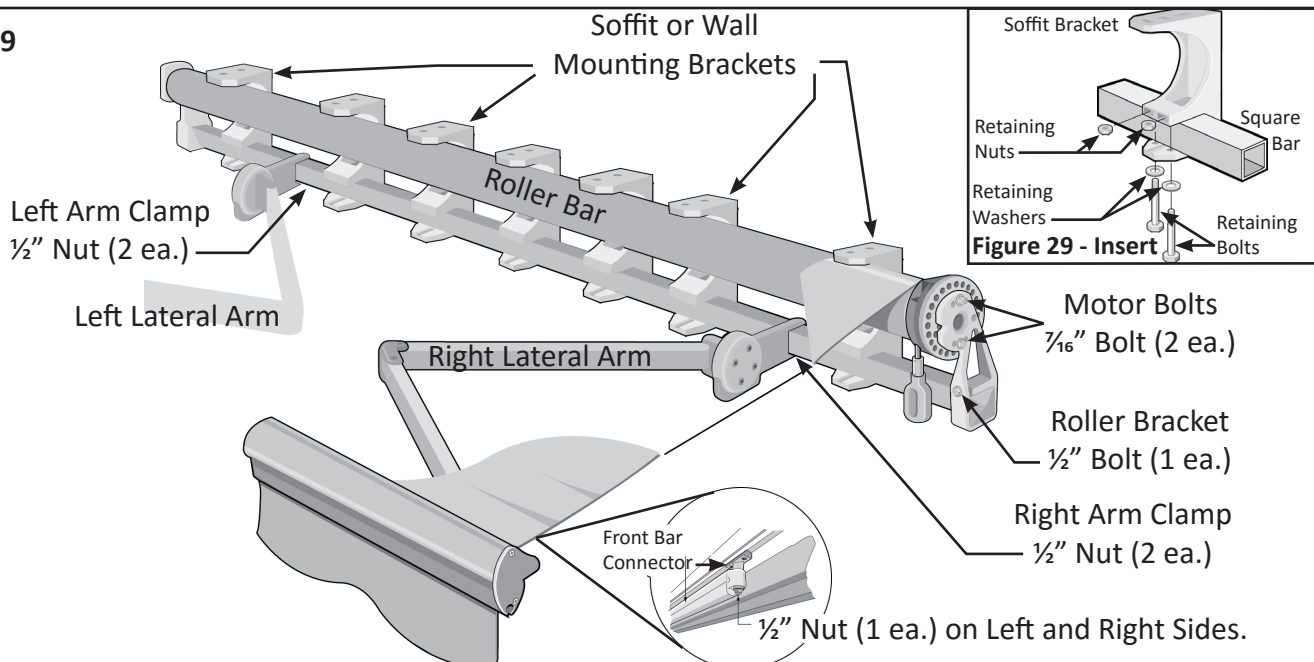

Figure 29



APPENDIX G - How to Safely Remove the Bungee Cords from the Cover

WARNING: IF YOUR COVER IS SECURED TO THE AWNING FRAME WITH BUNGEE CORDS OR ANY OTHER TIE DOWNS, FAILURE TO FOLLOW THESE INSTRUCTIONS WHEN REMOVING THE BUNGEE CORDS FROM THE COVER COULD RESULT IN PERSONAL INJURY.

1. To make sure that the Awning is **completely** closed under the Protective Cover, inspect the following conditions from the side of the Awning:

WARNING: DO NOT PLACE THE LADDER OR STAND IN FRONT OF THE AWNING. DOING SO COULD RESULT IN PERSONAL INJURY.

- a. Check to make sure that the Fabric between the Front Bar and the Roller Bar is tight. See **Figure 30**.
 - b. If the Fabric is loose or sagging (see **Figure 31**), push the CLOSE button on your Remote Transmitter or use the manual hand Crank Wand to fully close the Awning and wrap the Fabric tightly around the Roller Bar.
 - c. Check that the Fabric is now tight between the Front Bar and Roller Bar. See **Figure 30**.
2. Position yourself under the Awning. Remove the Bungee Cords one at a time.
3. Test the operation of your Awning using the OPEN and CLOSE buttons on the Remote Transmitter.

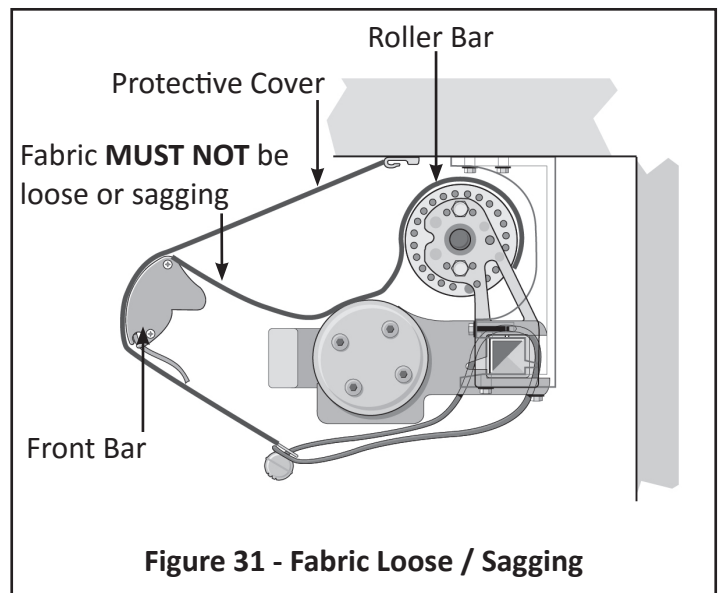
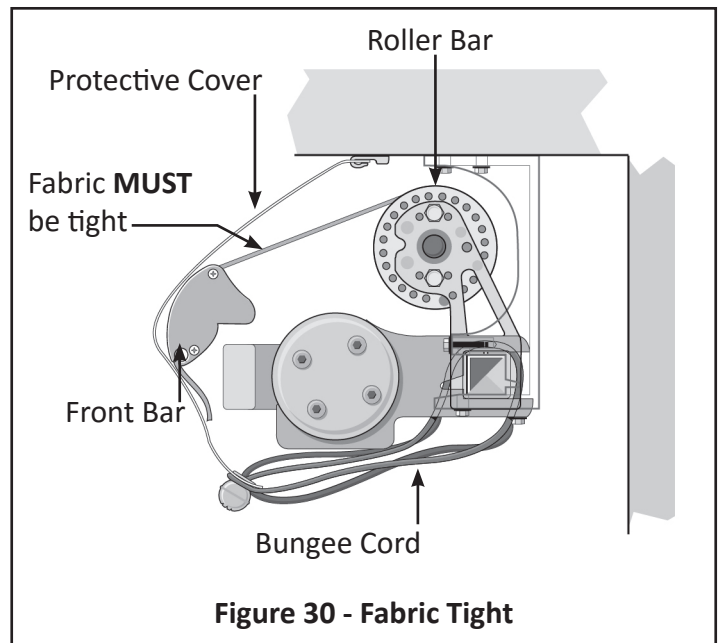

A Place for Your Notes

5-Year Limited Warranty-Awning and Accessories VISTA and Motorized Models Only

A. WHO GIVES THIS WARRANTY?

SunSetter Products, 184 Charles Street, Malden, MA 02148.

B. WHO IS ENTITLED TO THIS WARRANTY?

This Warranty applies only to the original purchaser who paid for the product and may not be assigned or transferred to subsequent owners. This Warranty applies only to products purchased and installed in the US.

C. WHAT ARE THE RESPONSIBILITIES OF SUNSETTER PRODUCTS UNDER THIS WARRANTY?

Subject to the terms and conditions set forth herein, SunSetter Products will furnish replacements for parts found by SunSetter Products to be defective in design, manufacture or assembly, under each specific component or product warranty as set forth below.

D. WHAT ARE THE RESPONSIBILITIES OF THE ORIGINAL PURCHASER UNDER THE WARRANTY?

1. Before any claims may be made under this Warranty, the original purchaser must have paid in full for the product covered under the Warranty, according to the terms and conditions of the pay-plan defined in the original order. **IF THE PURCHASER HAS FAILED TO MAKE FULL PAYMENTS ACCORDING TO THE SPECIFIC PAY PLAN FOR THE PRODUCT, THIS WARRANTY SHALL BE NULLIFIED AND SUNSETTER PRODUCTS SHALL BE RELIEVED FROM ANY RESPONSIBILITY OR LIABILITY UNDER THIS WARRANTY.** The purchaser agrees and acknowledges that this Warranty agreement constitutes an executory contract.

2. The purchaser must use care in installation, maintenance, operation, use, and storage of the product in accordance with the instructions contained in the owner's manual. **ANY FAILURE TO INSTALL, MAINTAIN, OPERATE, USE AND STORE THE PRODUCT IN ACCORDANCE WITH THE INSTRUCTIONS CONTAINED IN THE OWNER'S MANUAL WILL NULLIFY THIS WARRANTY AND RELIEVE SUNSETTER PRODUCTS FROM ANY RESPONSIBILITY OR LIABILITY UNDER THIS WARRANTY.**

3. Promptly notify SunSetter Products of any claims.

4. The purchaser may be required to provide a photograph of any defective parts. The purchaser may also be required to pay a deposit until the defective parts are returned to SunSetter Products for inspection. The purchaser must obtain a Return Authorization form from SunSetter Products' customer service department prior to the return of any merchandise and after having received such authorization, return the part or product, freight prepaid, to SunSetter Products.

E. WHAT IS COVERED UNDER THIS WARRANTY?

1. The following components of the SunSetter Lateral Arm Awning and its accessories (defined as accessories attached to the awning) are covered under this Warranty, subject to the limitations set forth below. These components have a five (5) year limited (prorated) warranty, against manufacturer's defects as outlined below:

(a) Should the purchaser promptly notify SunSetter Products of such defects within one year (12 months) from the date of the original purchase, the defective component will be replaced at no charge.

(b) After one year but within five years (60 months) from the date of the original purchase, a defective component will be replaced upon the purchaser's payment of 1/60th of the full retail cost of the component for each month of use prior to the claim.

2. Covered Components:

STRUCTURAL SUPPORTS, which include the Lateral Arms, the Square Bar, the Front Bar and all other attached supports are warranted not to fail for five (5) years provided that the components are not subjected to excessive winds or water pooling on the Fabric.

ROLLER BAR is warranted for five (5) years against any and all damage including cracking and permanent bowing that would affect the performance of the Awning, provided that the Awning is not subjected to excessive winds or water pooling on the fabric.

FABRIC is warranted for five (5) years against:

(a) Excessive fading under normal conditions if maintained, operated, used, and stored in accordance with the instructions contained in the Owner's Manual & Installation Instructions.

(b) Mildew on the fabric. Mildew will not form on the fabric itself, but may form on dirt and dust that have not been removed from it. Please see maintenance instructions for proper cleaning-out-lined in owner's manual.

(c) Excessive cracking or peeling under normal conditions if maintained, operated, used, and stored in accordance with the instructions contained in the Owner's Manual & Installation Instructions, and provided that the Awning is not subjected to excessive winds or water pooling on the fabric.

GEAR MECHANISM (VISTA Model only) is warranted for five (5) years not to fail under normal conditions if maintained, operated, used, and stored in accordance with the instructions contained in the Owner's Manual & Installation Instructions.

ELECTRIC MOTOR (Motorized Models only) is warranted for five (5) years not to fail under normal conditions if maintained, operated, used, and stored in accordance with the instructions contained in the Owner's Manual & Installation Instructions.

AWNING ACCESSORIES (defined as accessories attached to the Awning) are warranted for five (5) years not to fail under normal conditions if maintained, operated, used, and stored in accordance with the instructions contained in the Owner's Manual & Installation Instructions.

F. WHAT IS NOT COVERED UNDER THIS WARRANTY?

1. The SunSetter Awnings are not designed to be used for carports and are not designed to be installed on moving vehicles. Any damage that results from the Purchaser's use of SunSetter Awnings for carports or on moving vehicles is not covered by this warranty.

2. Any failure or damage of the components that results from any intentional or negligent actions by the purchaser or by any other person is not covered by this Warranty.

3. It is the responsibility of the purchaser to securely fasten the Awning to studs, joists, headers or other structural members. Any failure or damage that results from the Awning falling from its installed position is not covered by this Warranty.

4. Labor charges connected with installation of replacement parts are not covered by this Warranty.

5. Freight expenses to and from SunSetter Products, in shipping damaged or replacement parts, are not covered by this Warranty and must be paid by the purchaser.

6. Stretching of Fabric or damage to any structural component caused by wind or water pooling on the Fabric or any other weather are not covered by this Warranty.

7. Any modification or addition to the Awning structure and support system or to the electric motor will nullify this Warranty and relieve SunSetter Products from any responsibility or liability under this Warranty.

G. GENERAL PROVISIONS AND LIMITATIONS

1. THE WARRANTY GRANTED HEREIN IS THE EXCLUSIVE REMEDY FOR THE PURCHASER. SUNSETTER PRODUCTS MAKES NO OTHER WARRANTIES TO THE PURCHASER, EXPRESS, STATUTORY, IMPLIED OR OTHERWISE AND ALL IMPLIED WARRANTIES, INCLUDING WITHOUT LIMITATIONS, IMPLIED WARRANTIES OF MERCHANTABILITY AND FITNESS FOR A PARTICULAR PURPOSE, ARE HEREBY DISCLAIMED.

2. TO THE EXTENT PERMITTED BY LAW, SUNSETTER PRODUCTS SHALL HAVE NO LIABILITY TO THE PURCHASER OR ANY OTHER PERSON FOR INCIDENTAL, SPECIAL, CONSEQUENTIAL, INDIRECT OR SIMILAR DAMAGES OF ANY KIND OR NATURE WHATSOEVER, WHETHER ARISING OUT OF BREACH OF WARRANTY OR OTHER BREACH OF CONTRACT, NEGLIGENCE OR OTHER TORT, OR OTHERWISE, EVEN IF SUNSETTER PRODUCTS SHALL HAVE BEEN ADVISED OF THE POSSIBILITY OR LIKELIHOOD OF SUCH POTENTIAL LOSS OR DAMAGE. IN NO EVENT SHALL SUNSETTER PRODUCTS BE LIABLE FOR LOSS OF PROFITS AND/OR WAGES.

3. Some states do not allow limitations on how long an implied warranty lasts, or do not allow the exclusion or limitation of incidental or consequential damages, so the above limitations may not apply to you.

4. This warranty gives you specific rights and you may have other rights which vary from state to state.

Installer Checklist

1. Note and Report any Shipping Damage to SunSetter Products
2. **Set the Multi-Channel Remote Transmitter to Channel 1 to operate the Awning.**
3. Review Proper Awning Operation with Homeowner. See **Page 14.**
4. Review the Multi-Channel Remote Transmitter with Homeowner. See **Page 15.**
5. Cover or Aluminum Hood (If purchased) - Installed.
6. Open and Close Motor Stops - Set Correctly and Adjusted as Needed. See **Appendix A.**
7. Awning Pitch - Adjusted to fit Customer Needs. See **Appendix B.**
8. Fabric - Discuss Care, Adjust if Necessary
9. Wireless Wind Sensor (If Purchased) - Installed and Tested to Retract Awning when Front Bar is lifted and dropped, repeatedly.
10. Review 5-Year Limited Warranty - See **Pages 31 and 32.**
11. All Weather Warranty - Covers Weather Related Damage and Negligence for 5 Years.
12. **Leave this Owner's Manual with Homeowner.**

Important Customer Service Information

Congratulations on your SunSetter purchase. We hope that your SunSetter product has arrived in perfect condition, and that the installation and operation instructions we have provided help you to install and use your purchases with ease. If you still have questions, or need assistance from our Customer Service Department, please email us 7 days a week at contactus@sunsetter.com or call Toll Free at **800-670-7071**, from 8:00 AM to 10:00 PM (EST), 7 days a week. We'll be happy to help.

Thank you for choosing SunSetter