



For Technical support visit us at www.sunsetter.com/ownerscorner
or call Toll Free 800-670-7071 • Fax 877-224-4944

Motorized Oasis Awning RTS Motor Replacement Instructions *Helpers Needed*

Tools Needed: 7/16" Wrench, Step Ladder, Sawhorses or chairs, 9/16" Wrench.
Parts Supplied: Motor, (4) Plastic safety sleeves, 3mm Allen Wrench.

WARNING: FAILURE TO FOLLOW THESE INSTRUCTIONS CAN RESULT IN PERSONAL INJURY!! PLEASE READ THESE INSTRUCTIONS IN ITS ENTIRETY BEFORE ATTEMPTING TO COMPLETE THIS PROCEDURE.

NOTE: IF YOU CANNOT CLOSE YOUR AWNING USING THE CRANK WAND, COMPLETE THE FOLLOWING PROCEDURE (STEPS 1 THRU 5) AND THEN CONTINUE WITH STEP 8. IF YOU CAN CLOSE YOUR AWNING USING THE CRANK WAND, CONTINUE WITH STEP 6.

WARNING: MAKE SURE THAT NO ONE STANDS IN FRONT OF THE AWNING DURING THIS PROCEDURE, IN CASE THE AWNING SPRINGS OPEN.

1. Position a step ladder at the Motor end of the awning (Note: outside the awning, not under the awning) and align with the elbow of the Left Arm Assembly. See Figure 1

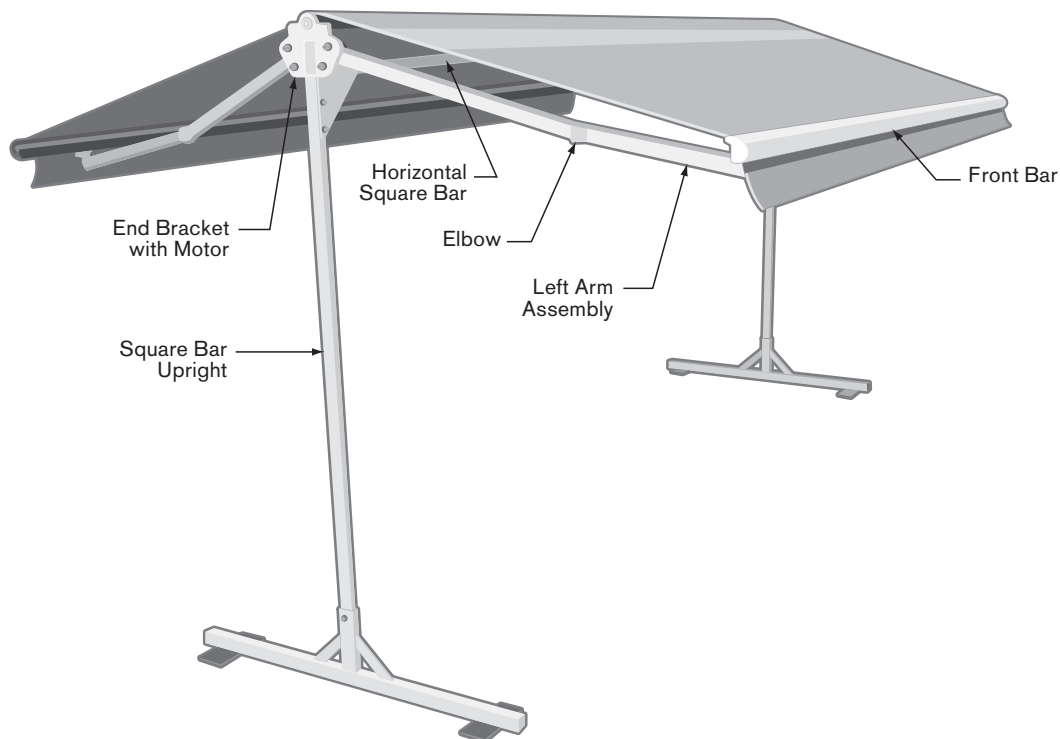
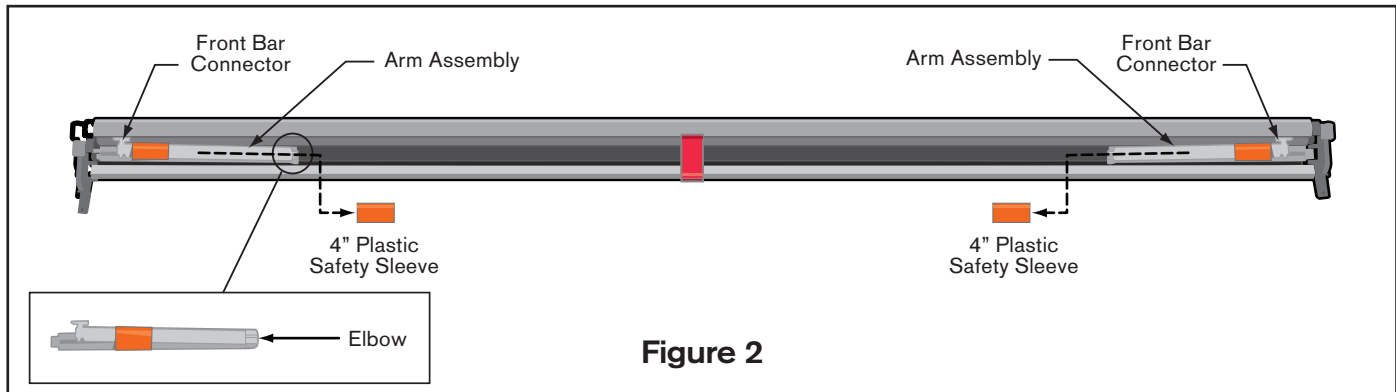

Figure 1

2. Unplug the power cord from your electrical outlet, and if installed remove the Cord Cover from the square bar upright.
3. Starting with the left arm assembly, push in on the elbow to start the arm to close and grasp the outside edge of the Front Bar and pull it in toward the End Bracket.
4. Continue to pull the Front Bar in until the Arm Assembly makes contact with the Horizontal square bar and is fully closed. Your Helper will now be able to slide one of the supplied safety sleeves on to the arm assembly until it contacts the Front Bar Connector. See Figure 2



5. Repeat the procedure for the remaining three arm assemblies and skip to step 8.

6. Make sure that the awning is completely closed, and remove the crank wand from the Override crank on the motor. Unplug the power cord from your electrical outlet, and if installed remove the Cord Cover from the square bar upright.

7. Slide the supplied safety sleeves on all four arm assemblies until they contact the Front Bar Connectors. See Figure 2.

8. Position two saw horses or chairs approximately 8 feet apart.

WARNING: THE FOLLOWING PROCEDURE SHOULD BE ACCOMPLISHED BY FOUR PEOPLE.

9. One person should be positioned at each leg assembly to prevent the awning from sliding as the unit is carefully tipped over.

10. One person should be positioned at each end of the awning assembly, and be able to lift and support the weight of that end of the awning.

11. When the helpers are in position, the two people positioned at the ends of the awning assembly should carefully tip the awning over until the awning is resting on the two saw horses or chairs. See Figure 3

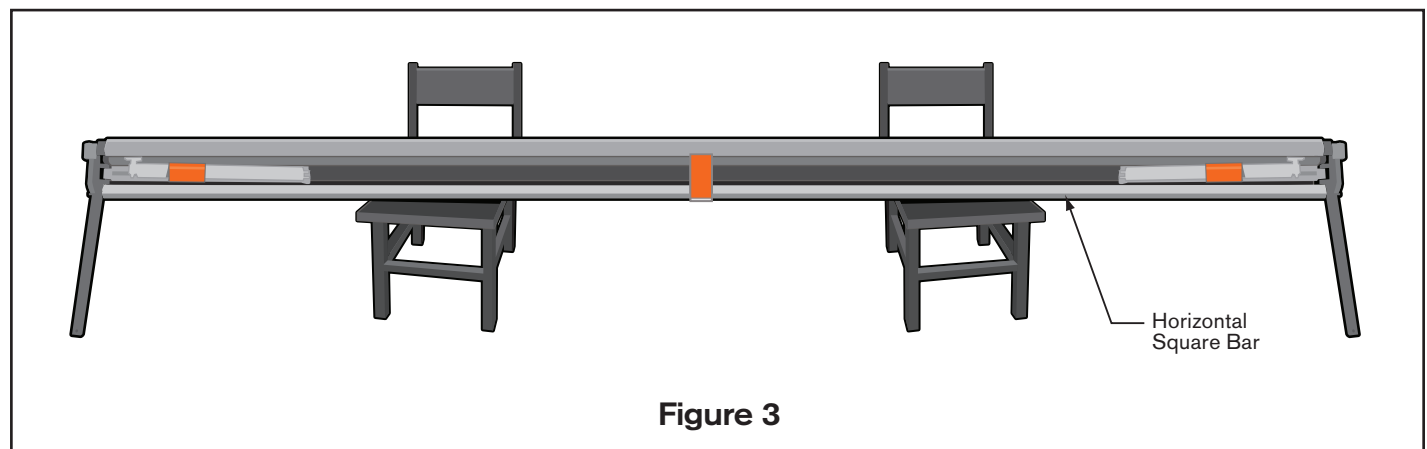

12. If your fabric is completely rolled up, use the crank wand to unroll about 3 inches of fabric. Remove the crank wand.

13. On the same end of the awning as the motor using a 9/16" socket and wrench, loosen but **Do Not Remove** the four bolts that secure the Corner brace to the Horizontal Square bar and the Square Bar Upright. See Figure 4.

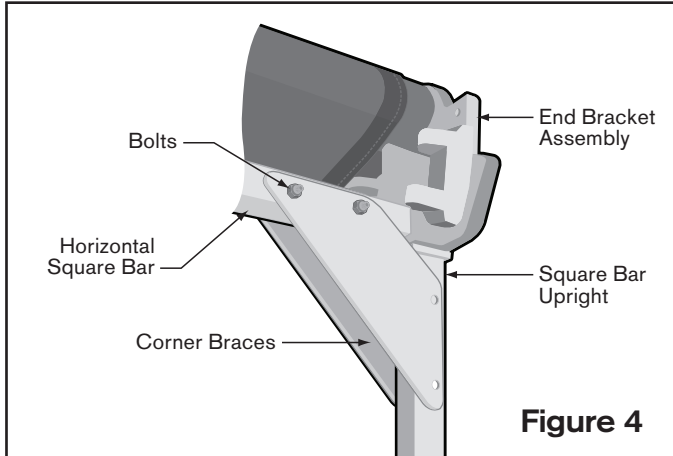

14. Locate the bolt on the Horizontal Square bar loosened in Step 13 that is farthest from the Square Bar Upright and remove it from the awning. See Figure 5. Now locate the two bolts that secure the Corner Brace to the Square Bar Upright and remove them from the awning. (This will allow the Corner Brace to be moved out of the way so that you have access to remove the old motor cord and properly align the new motor cord).

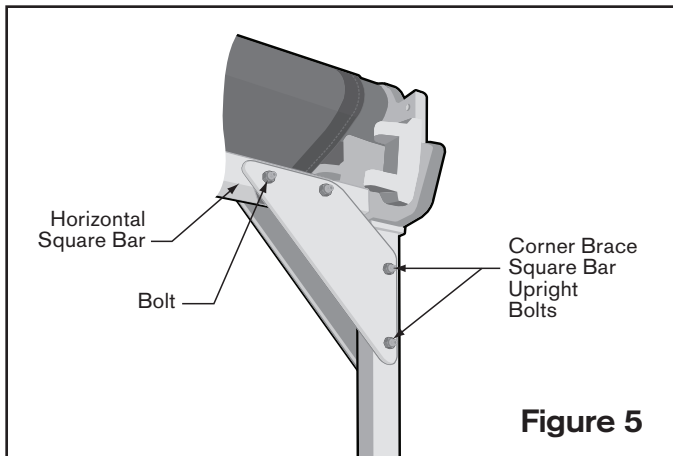

NOTE: Before performing the next step, note the orientation of the Motor on the End Bracket Assembly. See Figure 6

15. Have one helper hold the roller bar near the end bracket on the side that is opposite of the motor. This is necessary to keep the roller bar from coming out of the end bracket while the motor is unbolted from the other side.

16. While your helpers support both ends of the roller bar, remove the two 1/4-20 hex bolts and washers that connect the motor to the end bracket. **Note the holes in the end bracket that the bolts are removed from.** See Figure 6.

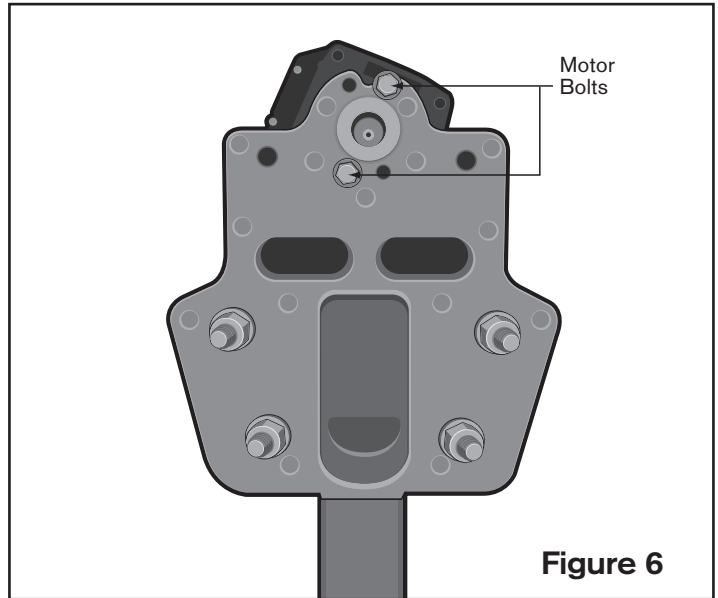

17. While a helper supports the roller bar near the motor, slide the motor assembly out of the roller bar. **Make sure that the other helper does not allow the roller bar to come out of the end bracket on the opposite side.**

18. Using the supplied 3mm Allen wrench remove the Override Crank from the old motor and install in the groove of the new motor with the Allen cap bolt and washer. See Figure 7

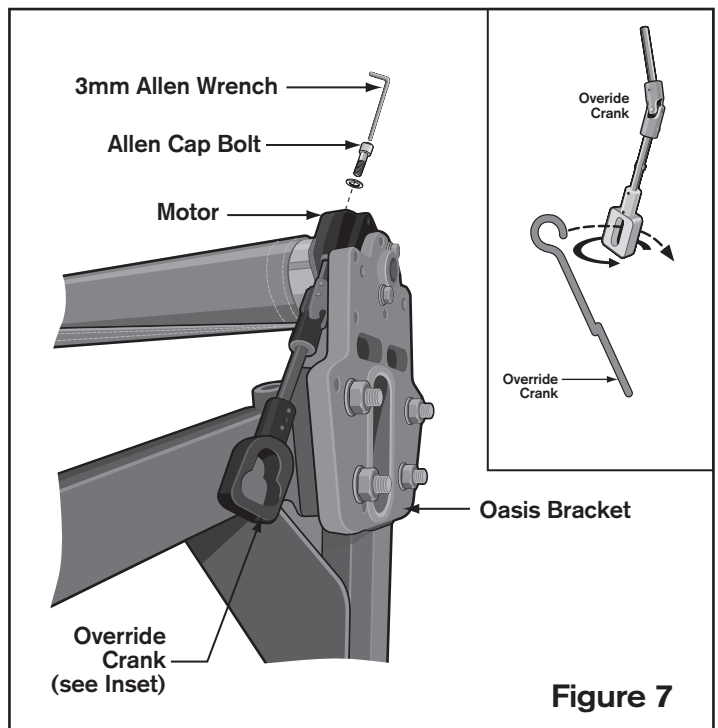

19. Insert the new motor into the roller bar, aligning the largest slot in the black tube drivers with the roller bar slot. See Figure 8. **Note: If the motor will not slide into the roller bar, you have selected the wrong slots.**

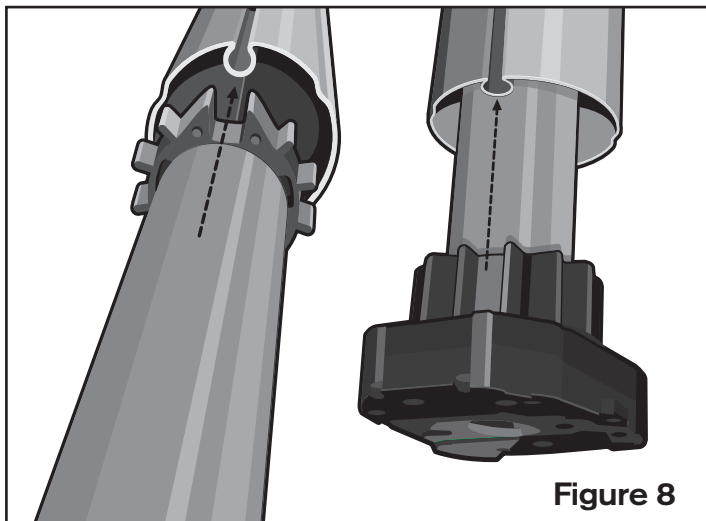

20. While your helpers support the roller bar, slide the roller bar toward the end bracket until the motor makes contact with the end bracket.

21. Attach the motor to the end bracket with the two 1/4-20 hex bolts and washers. Be very careful not to cross-thread the hex bolts, start the bolts by hand and finish tightening with the 7/16" wrench. The Open and Close Limit Buttons should be facing up.

22. Position the Motor Cord between the Corner Braces and the Horizontal square bar. See Figure 9

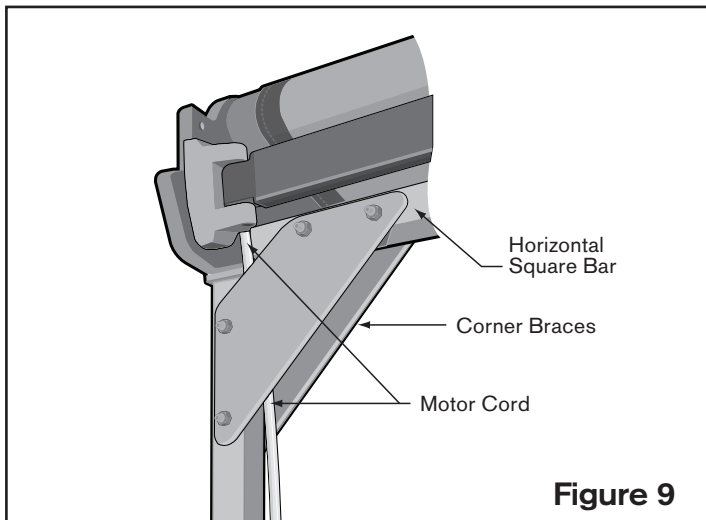

23. Align the holes in the corner braces with the Horizontal Square bar and Square Bar Upright and install the bolts and locknuts removed in Step 14. Securely tighten all bolts. See Figure 10

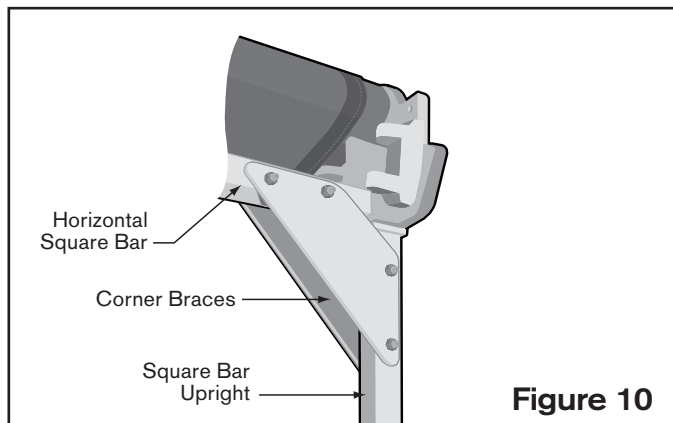

24. Use the manual crank wand to slowly roll the fabric onto the roller bar.

25. Carefully remove the four safety sleeves from the arm assemblies.

WARNING: THE FOLLOWING PROCEDURE SHOULD BE ACCOMPLISHED BY FOUR PEOPLE.

26. One person should be positioned at each leg assembly to prevent the awning from sliding as the unit is placed in the upright position.

27. One person should be positioned at each end of the awning assembly, and be able to support and lift the weight of that end of the awning.

28. When the helpers are in position, the two people positioned at the ends of the awning assembly should lift the awning together and tip the unit until the awning is upright on the leg assemblies.

29. Locate the Cord Cover and position the cover over the electrical motor cord and flat against the inside of the square bar upright. Secure in place with the Velcro straps.

30. Plug the electrical motor cord back into your ground fault interrupter (GFI) outlet.

WARNING: FAILURE TO PLUG THE ELECTRIC MOTOR CORD INTO A GROUND FAULT INTERRUPTER (GFI) OUTLET CAN RESULT IN PERSONAL INJURY.

31. Reset your existing remote transmitter to communicate with the new motor using the attached instructions.

32. Reset the motor stops using the attached instruction sheet.

33. Test the awning for proper operation.

Resetting the Remote Transmitter

This procedure describes the actions needed to reset the Remote Transmitter **that was supplied with your Motorized awning**. This procedure should only be performed if the Remote Transmitter does not operate the Motorized awning. Please review the steps below to familiarize yourself with the procedure before attempting to complete them.

1. Verify that the red light on the remote transmitter comes on when you press and hold the button. If the red light does not come on at all or blinks for less than 5 seconds, you will need to replace the battery (see Care and Maintenance section on page 13).
2. Press the NEUTRAL (middle) button on the transmitter.
3. Unplug the power cord from the wall.
4. Insert the wand into the Override crank on the motor and manually open the awning approximately 3 feet but do not completely open.
5. Plug the power cord back into the wall and make sure that there is electricity available. Let the awning sit **for one minute**, undisturbed, without pressing a button on the remote transmitter or unplugging the cord from the wall.
6. Unplug the power cord from the wall for 2 seconds.
7. Plug the power cord back in for 10 seconds.
8. Unplug the power cord for 2 seconds.
9. Plug the power cord back in and leave it plugged in.

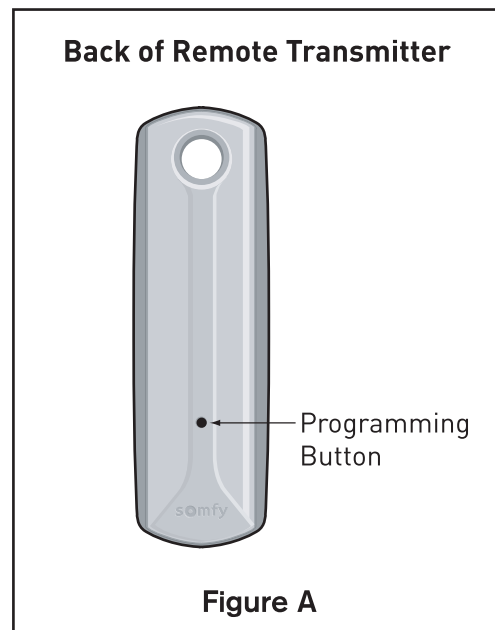

NOTE: The motor may rotate approximately 2 feet in one direction and stop.

10. When the motor stops, press and hold the programming button on the back of the Remote Transmitter (see fig. A) for 5 seconds until the motor 'jogs', then release. (A 'jog' is a short back and forth movement of the motor).

11. Activate the transmitter by pressing the OPEN and CLOSE buttons at the same time, the motor will jog.

12. Test Direction of motor rotation. The UP arrow must close the Awning. If it does not, hold the "MY" button until the motor jogs. This reverses the direction of the motor rotation. Test to ensure UP will CLOSE the Awning.

13. Press the programming button on the back of the Remote Transmitter until the motor jogs and release.

NOTE: If the motor does not operate, you will have to clear the OPEN/CLOSE stop settings on the motor. Complete **ONLY** steps 1 thru 5 of Appendix A (page 14). After clearing the OPEN/CLOSE stop settings, verify if transmitter operates the awning. If not, repeat the procedures listed above.

NOTE: Your Remote Transmitter is now reset to operate your Motorized awning. Test the awning for proper operation. If you cleared the OPEN/CLOSE stop settings on the motor, go to Appendix A on page 14 to reset them.

Add/Delete a Control Device (Transmitter)

To **ADD** an additional Control Device (not the one that was supplied with the awning).

- Press the programming button on the back of the transmitter that was supplied with the awning until the motor 'jogs' – see figure A.
- On the additional Control Device, press the programming button until the motor 'jogs', then release.

If you wish to **DELETE** a Control Device, simply repeat the 2 steps listed above.

Resetting the Limit Push Buttons on the SunSetter Motor

1. Press the Neutral/Stop button on the remote.
 2. Unplug the power cord from the electrical outlet.
 3. From a stepladder locate the limit push buttons on the motor. These push buttons will be on the top of the motor housing under a black plastic protective cap. See Figure 15.
 4. Grasp the black protective cap and lift it up. You will notice one yellow button and one white button inside a recessed area. These are the limit push buttons for the OPEN and CLOSE positions for the motorized awning.
 5. Clear the Factory Settings by separately pressing both buttons (white and yellow) until they are both 'IN' or at their lowest point inside the recessed area of the motor housing – see figure 15. You should practice this a few times to understand this process.
 6. Manually crank the awning open to the point where both sets of lateral arms 'lock' into the fully extended position. The fabric will also be at its tightest point.
- NOTE:** The fabric on the left side (as you face the motor) should be rolling from the bottom of the roller bar, and the fabric on the right side should be rolling over the top of the roller bar. See Figure 16. If the fabric is not as noted in figure 16, continue unrolling the fabric until the fabric on the left side is rolling from the bottom and the fabric on the right side is rolling over the top of the roller bar. Then roll up the fabric until the fabric becomes tight.
7. Depress the yellow button so that it is in the 'OUT' position (or closer to the top of the recessed area on the motor housing). Now the OPEN position stop is set.
 8. Manually roll the awning up until it is almost completely closed. The area to watch for is when the elbows of the arm assemblies come in contact with the horizontal square bar.
 9. Depress the white button so that it is in the 'OUT' position (or closer to the top of the recessed area on the motor housing). Now the CLOSE position stop is set.
 10. Replace the black protective cap on the motor housing. Be careful that the cap will not accidentally depress one of the push limit buttons underneath.
 11. Plug the power cord back into the electrical outlet.
 12. Test the awning for proper operation.

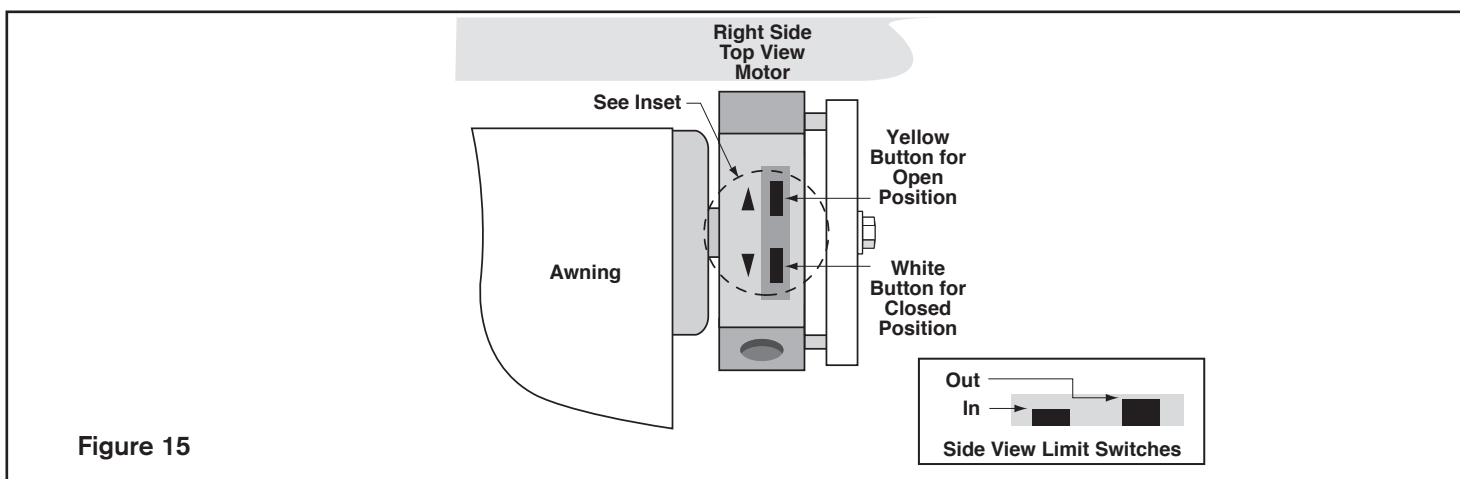

Figure 15